

APPROVED FOR MANUFACTURE

SIGNED..... DATE.....

PLEASE PRINT NAME.....

CHANGES MADE AFTER APPROVAL MAY BE CHARGEABLE

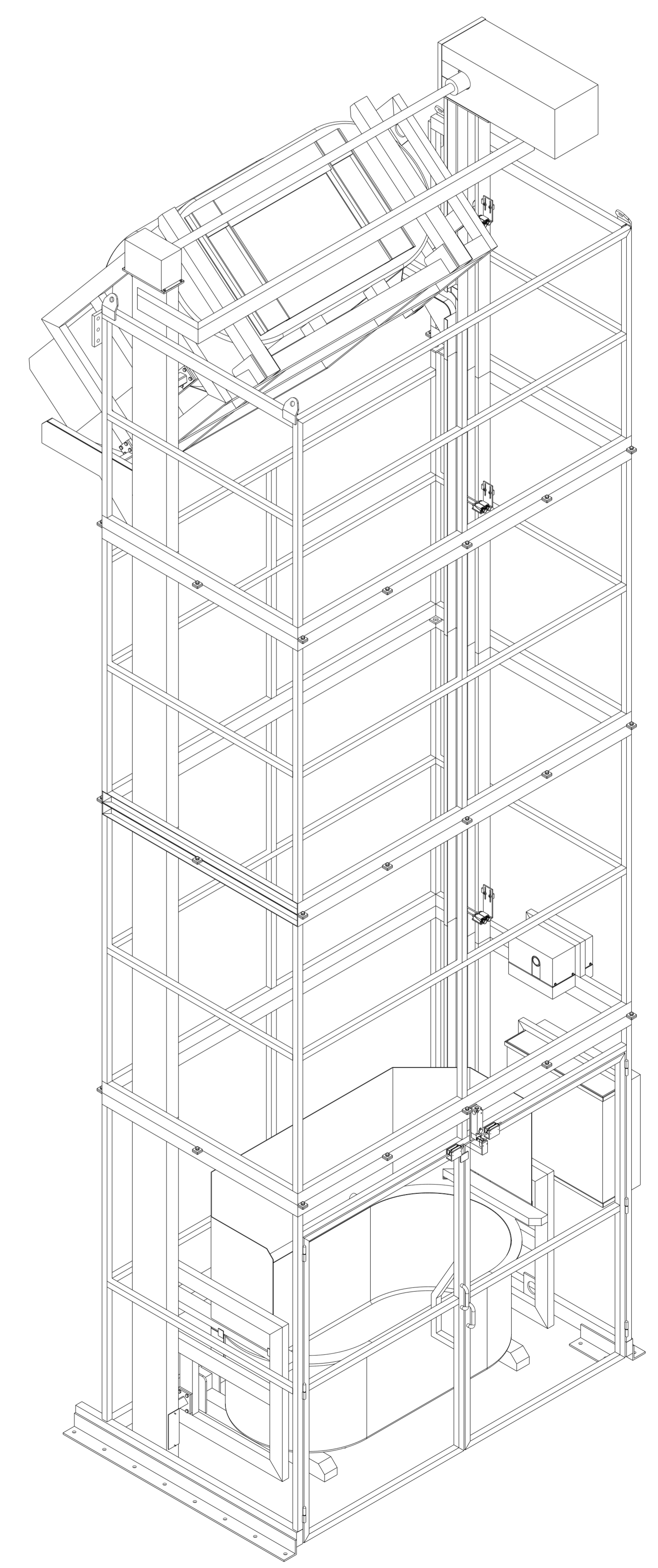
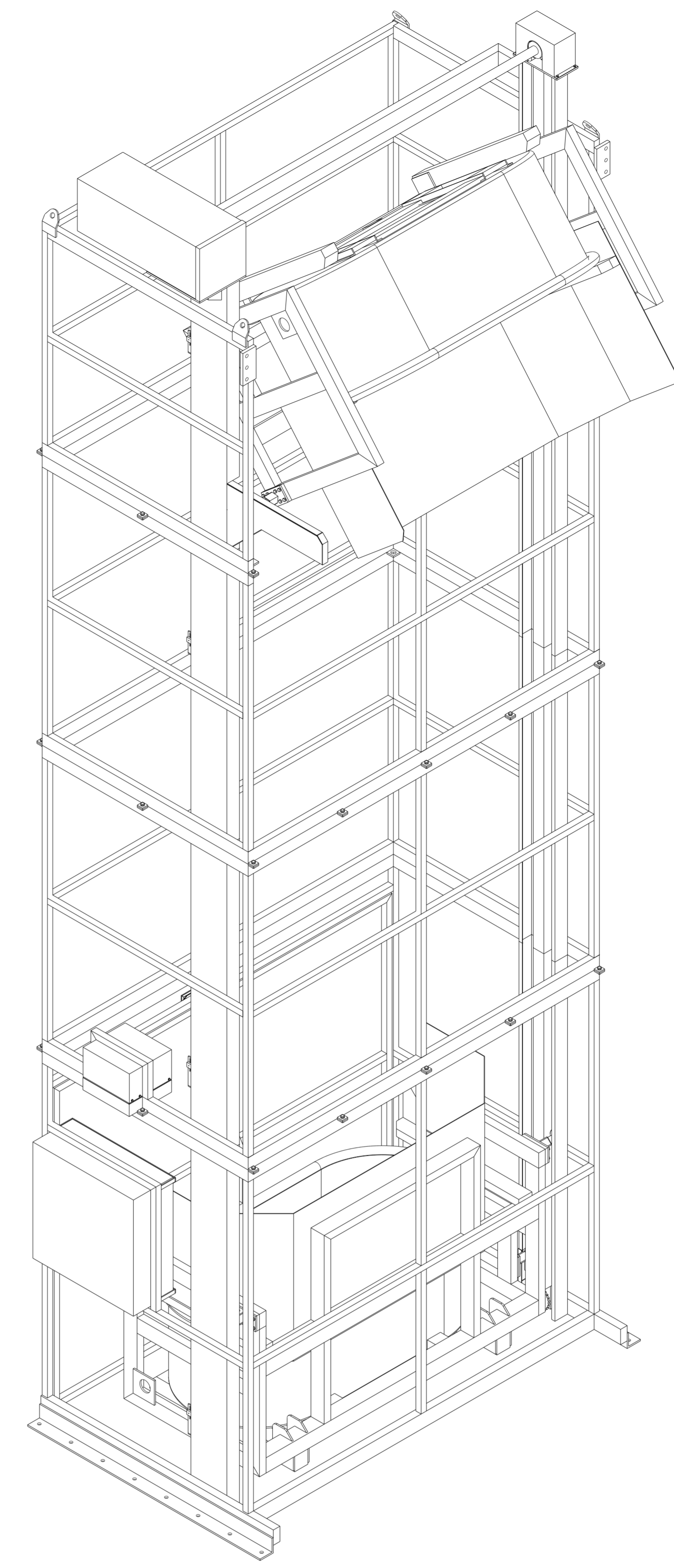
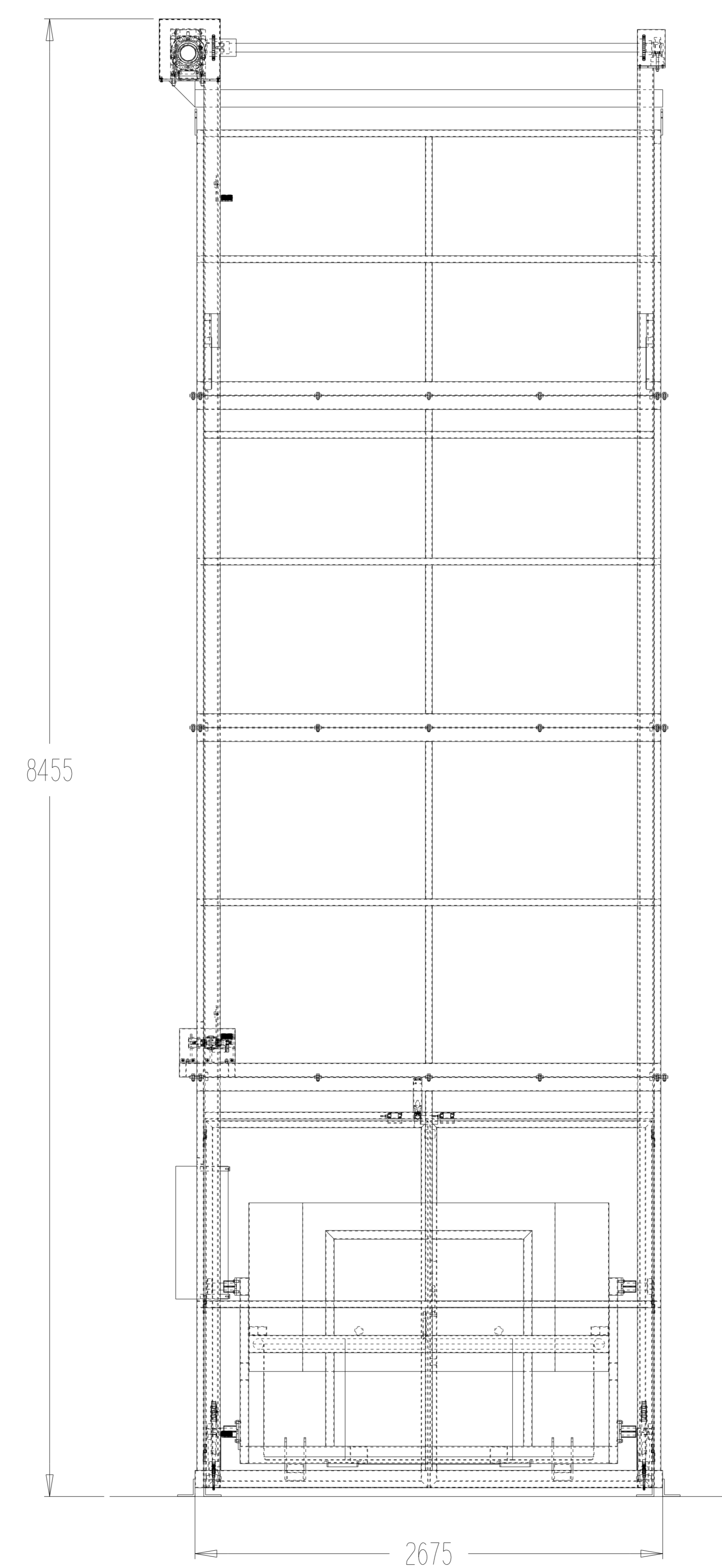
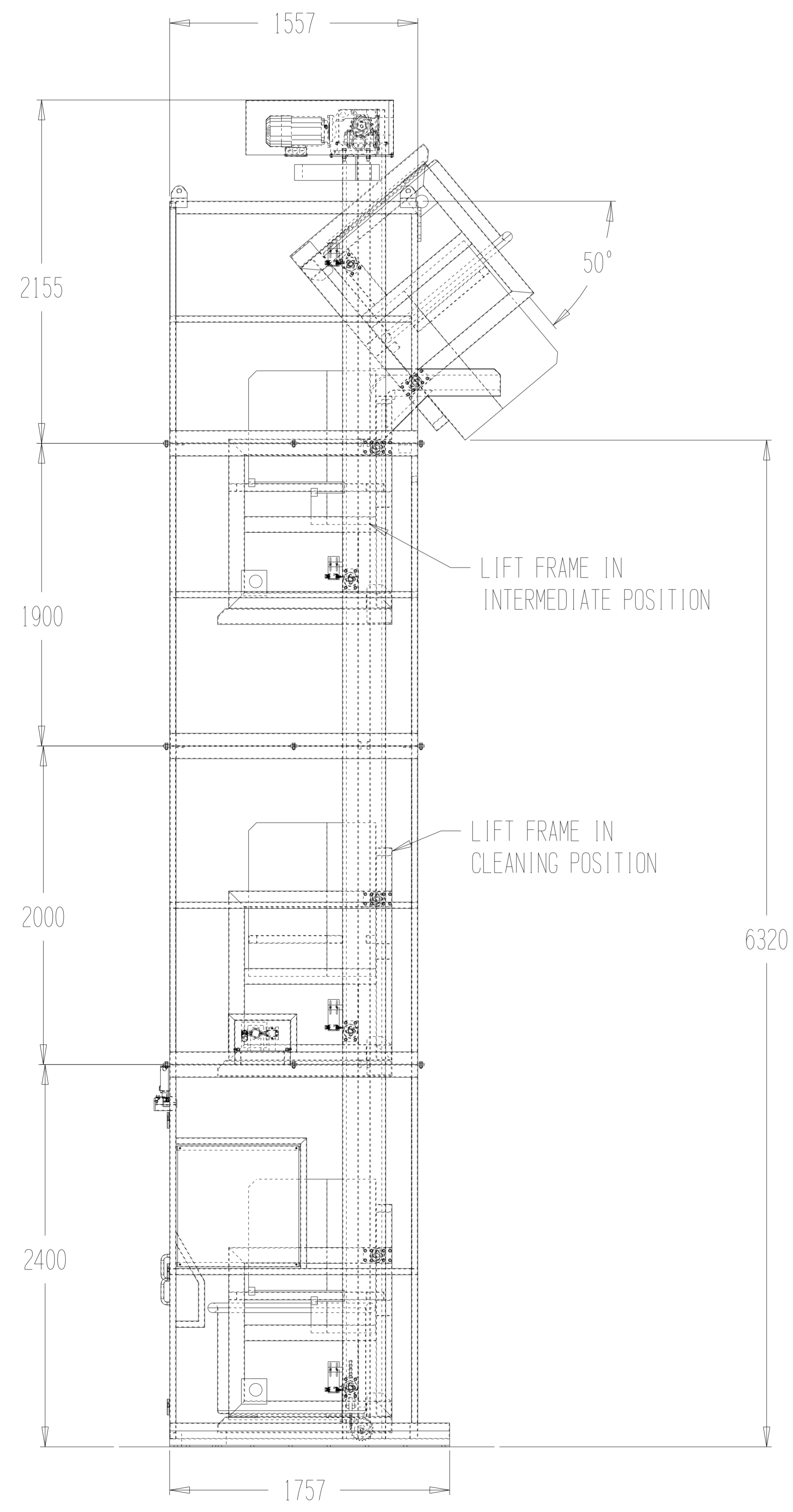
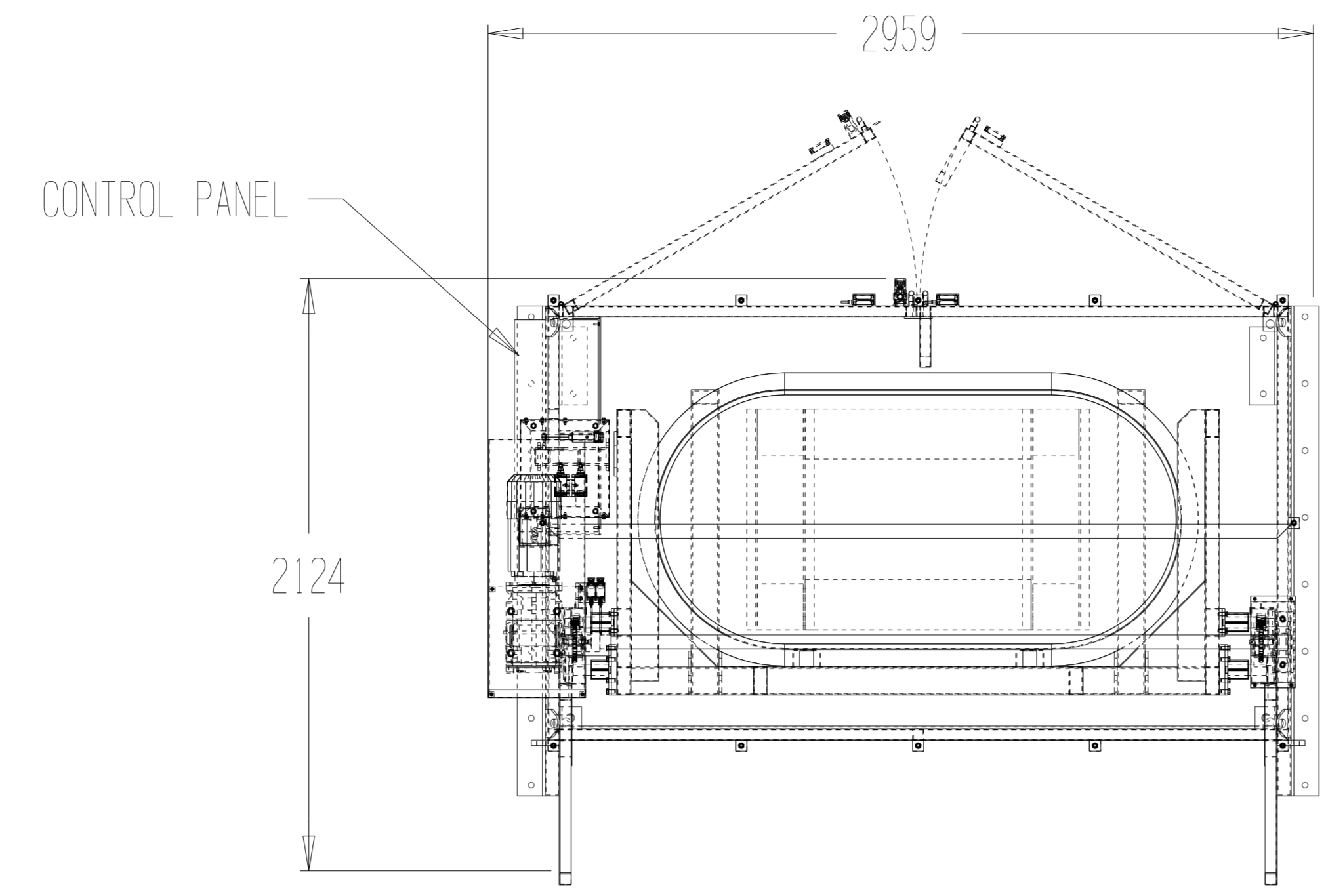

REVISION NUMBER	REV1 13-01-23 JPW REVISED	REV2 09-06-23 JPW REVISED			
CUSTOMER	DRAWING TITLE				
	GENERAL ASSEMBLY				

**WELDING NOTE**  
 STAINLESS STEEL MATERIAL UP TO AND INCLUDING 3mm THICK TO BE TIG WELDED AND MATERIALS OVER 3mm THICK ARE TO BE MIG WELDED UNLESS OTHERWISE STATED.  
 REFER TO WELDING PROCEDURES FOR MORE DETAIL

REMOVE ALL BURRS AND SHARP EDGES	DRAWN	CHECKED	DATE
TOLERANCES : UNLESS OTHERWISE STATED	JPW		12-12-22
FABRICATIONS : +/- 2.0mm	DRAWING NUMBER		
MACHINING : +/- 0.2mm	BP4494-1		
SHEET METAL WORK : +/- 1.0mm AND +/- 1.0 DEG			
DRAWN THIRD ANGLE PROJECTION			