

# ROTO 4676 FB

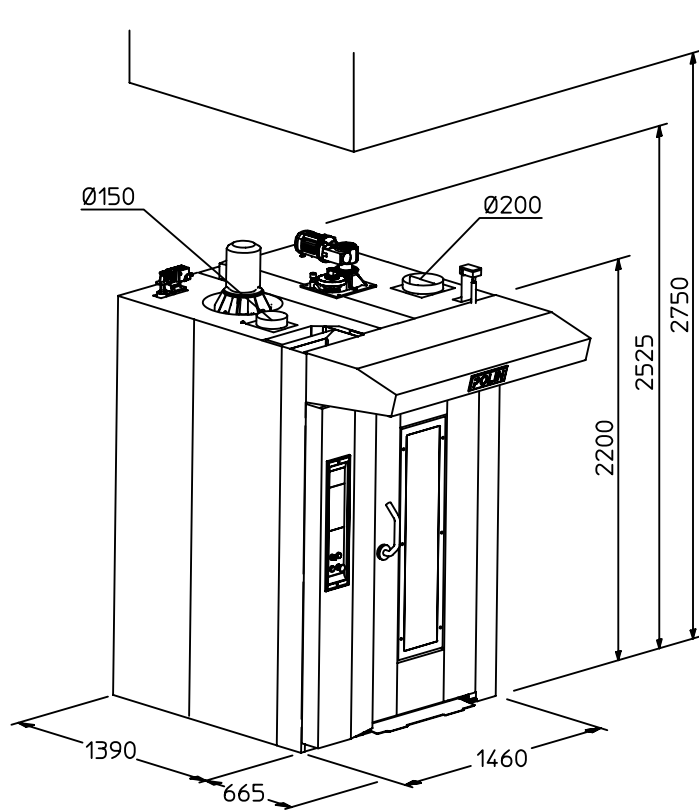

- Heat generator with front access
- Integrated electric board with front access
- Door with double glass and double lock
- Outside panels in st/st
- Oven shipped in 2 preassembled elements or completely assembled (as option)
- Automatic steam exhaust system (Fast Air)
- Automatic start
- Hood with exhaust fan and grill
- Double glass door end double closing
- Standard rotation device with hook (for racks up to 100 kg full load)
- Heat generator with armored electric elements (SE)
- Steam generator with cascade elements with spheres + liter-counter
- Preset for automatic lifting group by lever (optional)
- Racks height 1815 mm

Power inlet	220/3N~/60
Fume exhaust	Diameter 200 mm
Steam exhaust	Diameter 250 mm



	Pan capacity	Pan size	Minimum door width	Weight	SC Version		SE Version
	n°	mm	mm	kg	kW	BTU/h	kW
<b>ROTO 4676-FB</b>	20	460x660	770	1500	1.0	180,000	39