

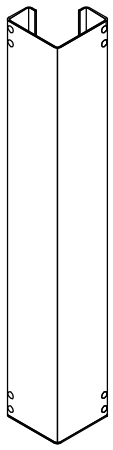

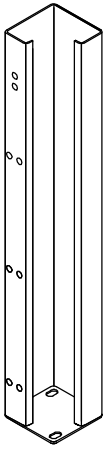
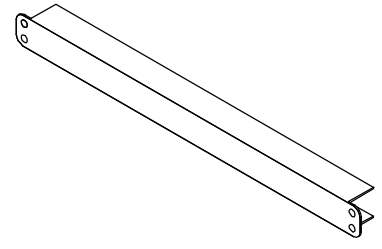
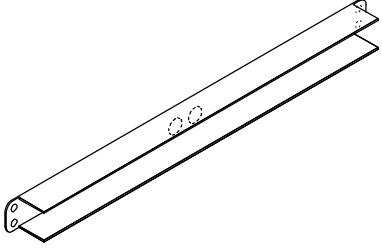
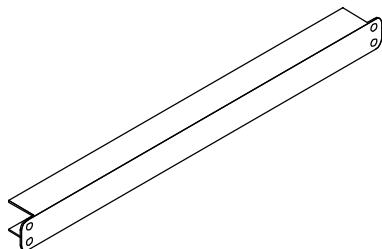

ROFCO Oven Stand

<p>#1</p>  <p>Front column x2PCS</p>	<p>#2</p>  <p>Rear column x2PIECES</p>	<p>#3</p>  <p>(Short) Left and right link plates x 4PCS</p>
<p>#4</p>  <p>rear link plates x2PCS</p>	<p>#5</p>  <p>(Long) Front link plates x 2 PCS</p>	<p>#6</p>  <p>The 4 screws corresponding to 4x#10screws.</p> <p>central back support x1PC</p>
<p>#7</p>  <p>tray runners x6PCS</p>	<p>#8</p>  <p>Pull out trayx1PC (with 2pcs support rail plates and 2 pcs slide rails)</p>	<p>#9</p>  <p>Φ6 screws x32PCS</p>
<p>#10</p>  <p>Φ5 screws x36PCS</p>	<p>#11</p>  <p>wheels x4PCS</p>	<p>#12</p>  <p>Corner platex4 PCS</p>
<p>#13</p>  <p>Φ8 screws x16PCS</p>		

1 Install wheel with brake into front column #1

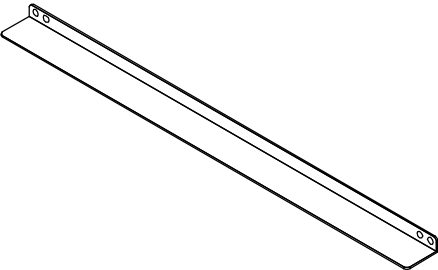
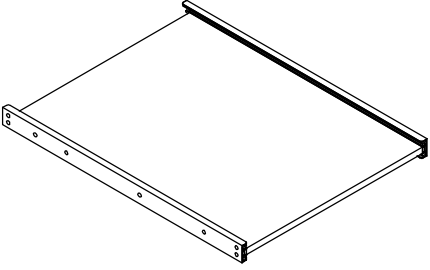
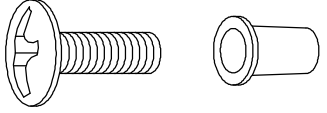

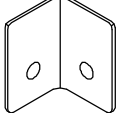
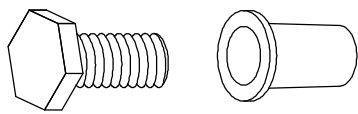
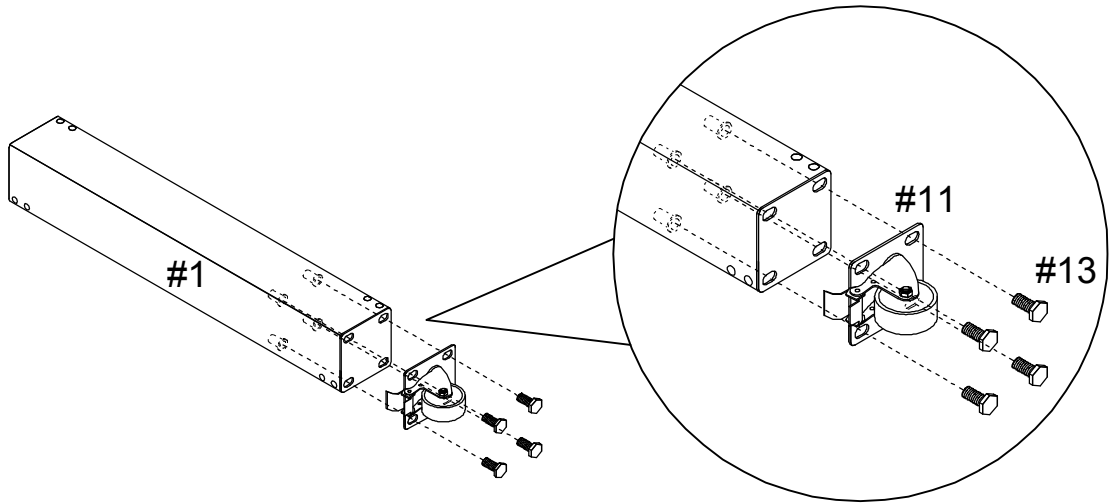
2 Install wheel with no brake into rear column #2

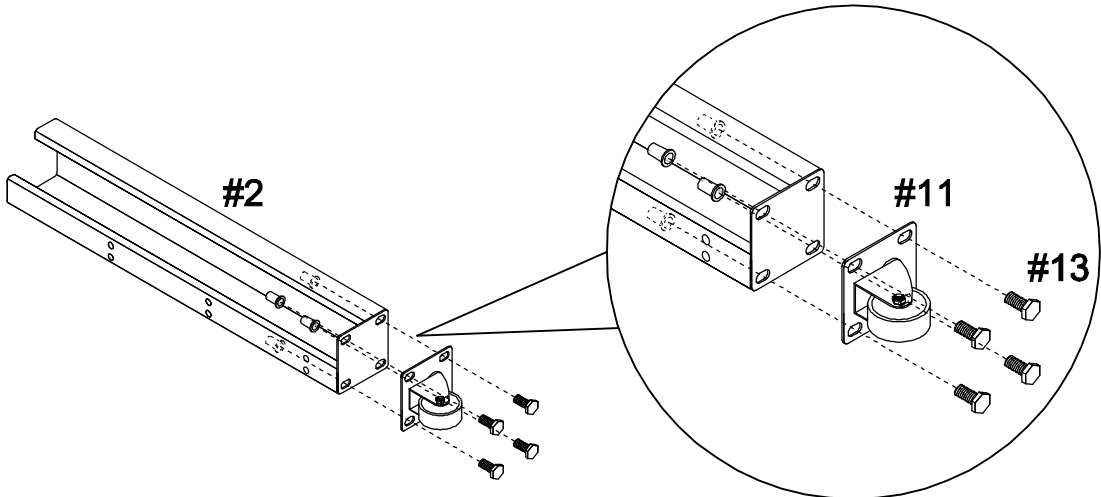

3 Link together front column #1, rear column #2 and Left and Right Link Plates #3

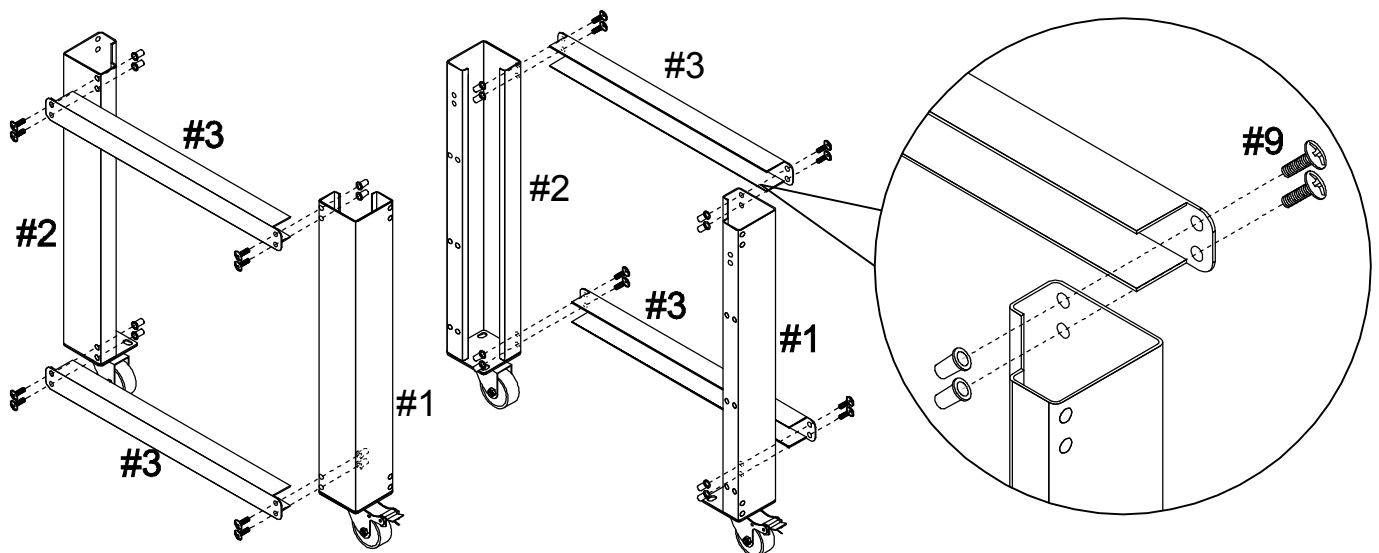

4 Install three tray runners#7 on the left and right sides respectively, three layers in total, two on each side.

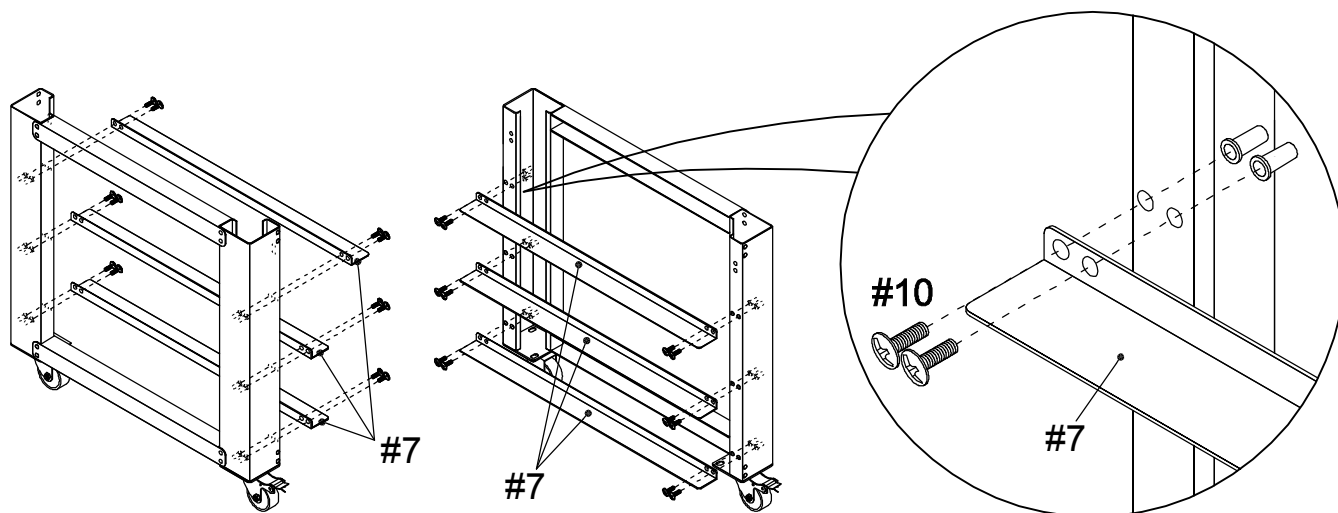

5 Rear assembly: Combine two rear link plates #4 with central back support #6

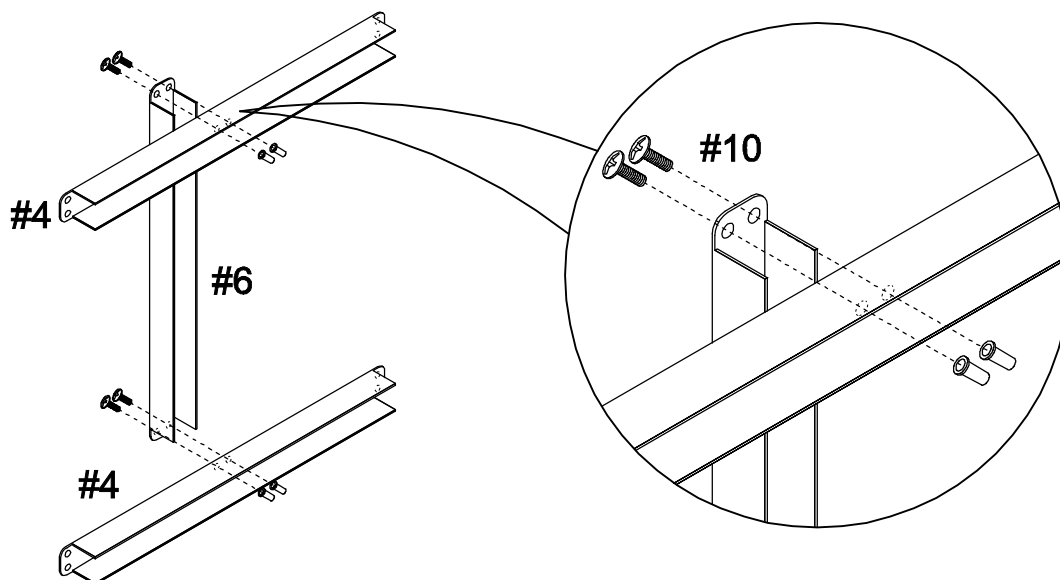

6 Connect the rear assembly above in step 5 with the rear main support columns #2

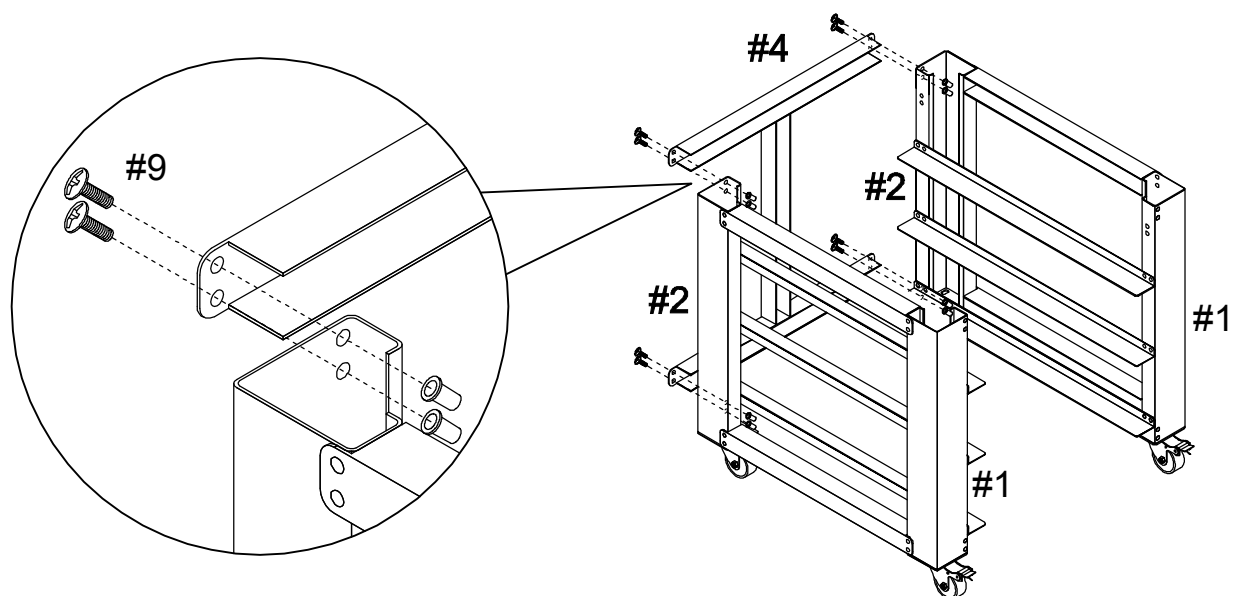

7 Install two front link plates #5

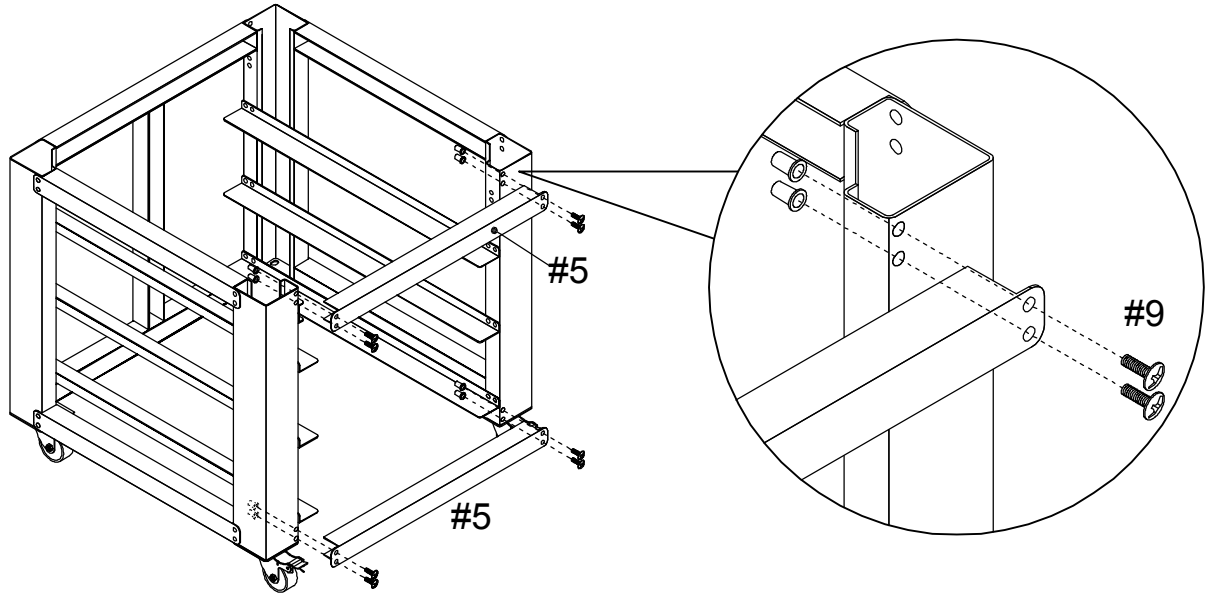

8 Slot pull out tray into guides on main frame. pull out drawer" is coming pre assembled.

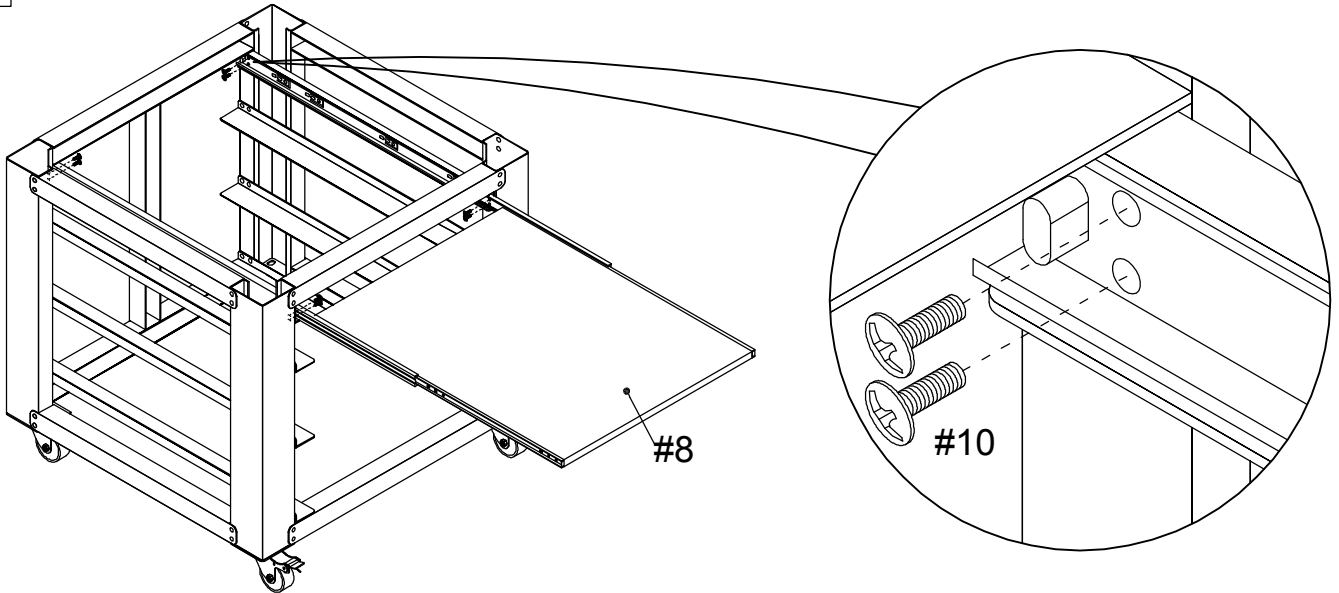

9 Attach the corner plate to the top of the shelf with Ø5 screw.

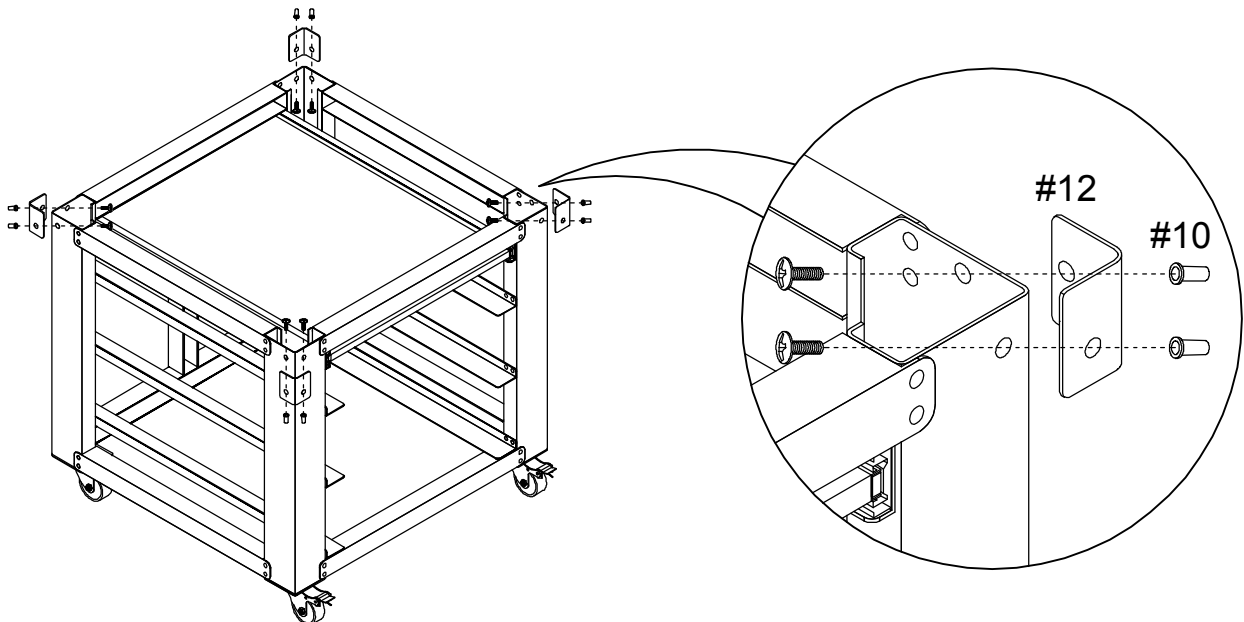

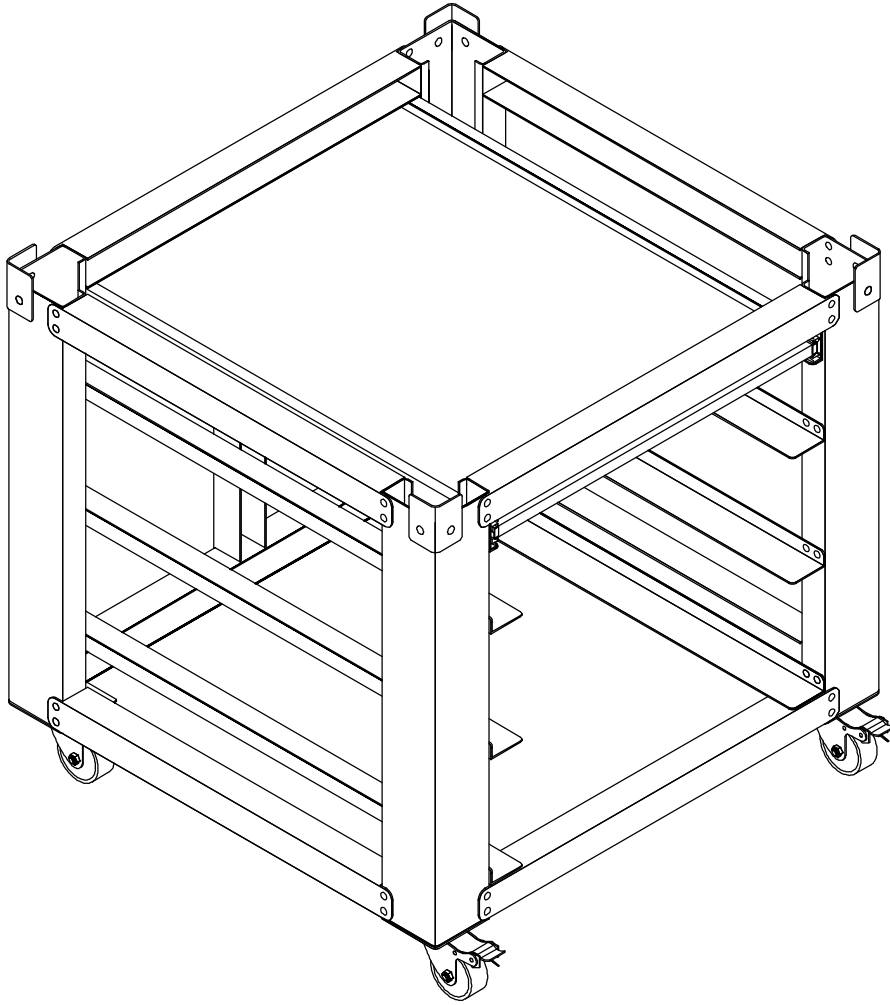
**Note:**

1. Size of screw

Φ5: Width of screw body: 5mm (0.197"), length: 15mm (0.591") ;

Φ6: Width of screw body: 6mm (0.236"), length: 15mm (0.591") ;

Φ8: Width of screw body: 8mm (0.315"), length: 15mm (0.591") .

2. The biggest screws in the bag are installed on the wheels of the stand, one wheel corresponds to 4 screws. The biggest screw is Φ8 screw, 16 Φ8 screws corresponds to four wheels.

3. Rivet Nuts already installed in metal.