

# ROTO AVANT



- Modular steam generator, with cascade elements with spheres
- Steamers with automatic feed
- Hood with potentiated exhaust fan
- Door with double glass and double closing
- Heat exchanger with armored heating elements (SE)
- Standard rotation device with hook
- Electric board with extended cables to hang it on oven's sides
- Oven with burner on the right is available (optional)
- Preset for automatic lifting group by lever (optional)
- Racks height 1925 mm

Power inlet	220/3N~/60
Fume exhaust	Diameter 200 mm
Steam exhaust	Diameter 250 mm

# ROTO AVANT HR 80100

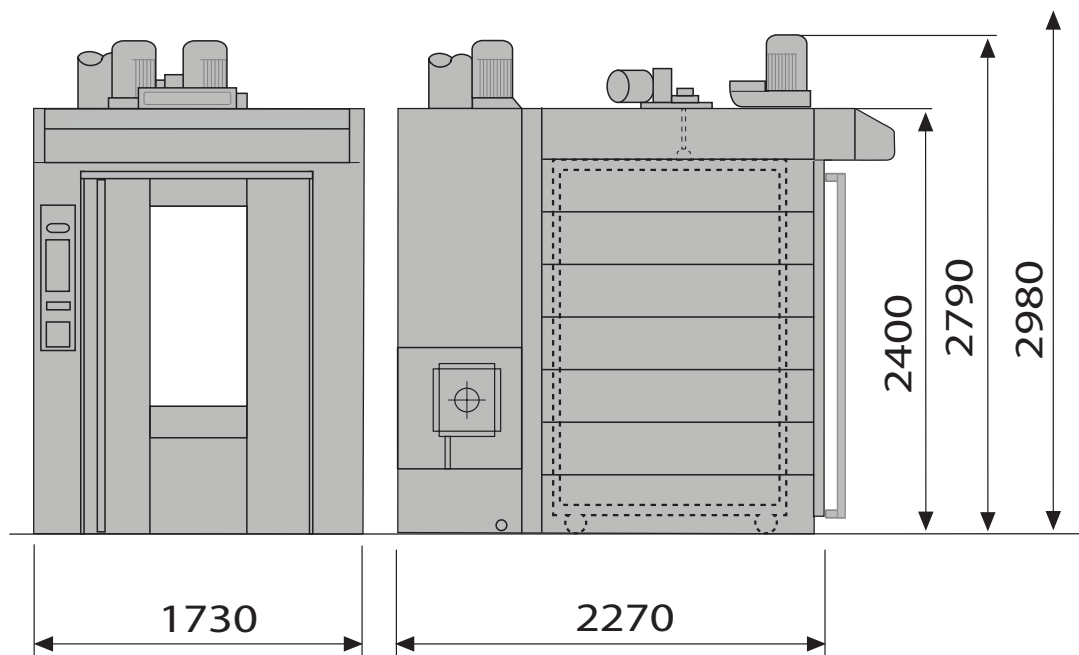

	Pan capacity	Minimum door width	Weight	SC version		SE version	
				kW	BTU/h	Standard	Potentiated
	n°	mm	kg			kW	kW
<b>ROTO AVANT HR 80100</b>	60	840	1900 SC 1850 SE	2.5	320,000	63.0	-