

CONVE_664TS

SIX-TRAY, FULL-SIZE COMBI OVEN

WITH TOUCH SCREEN AND DIAL CONTROLS



FEATURES

- (6) 18" x 26" tray capacity with 3 5/32" pitch
- (12) GN 1/1 (hotel/12"x20") tray capacity side-by-side (on grids)
- (12) Half-size (13"x18") tray capacity side-by-side (on grids)
- Two-year parts & labor warranty *INCLUDED*
- Wi-Fi connectivity *INCLUDED*
- Electrical cord and plug *INCLUDED*
- Installation kit *INCLUDED*
- (3) 18" x 26" stainless-steel grids *INCLUDED*
- Integrated automatic wash system *INCLUDED*
- Removable multi-point core probe *INCLUDED*
- Temperature range 86°F to 518°F
- (2) Bi-directional fan
- 500 multi-step program capacity
- Pre-installed/customizable programs
- AISI 304 stainless-steel cooking chamber
- Standard door is left-opening (hinged-right)
- Door rests at 60°, 90°, 120°, 180°
- Stackable with CONVE_664TS or CONVE_464TS
- Adjustable feet
- Extended warranty options available

Conforms to the following standards:

- Standard safety UL 197-2014
- Sanitation NSF / ANSI 4-2014
- Sanitation NSF / ANSI 170-2010
- Sanitation NSF / ANSI 51-2012
- CSAC 22.2 No. 109-M1981
- IEC standard 60529: IPX5



CONVE_664TS

DIMENSIONS NET AS SHIPPED

	NET	AS SHIPPED
Width	33.465 in	36 in
Depth	40.790 in	43 in
Height	35.240 in	41 in
Weight	237.6 lb	299.0 lb

UTILITY CONNECTIONS

All utility connections should be within three feet of the centerline of the back of the oven when installed.

Water supply: 1/2" cold-water supply (max 86°F) with supplied 3/4" NPT or 3/4" GH/NHR connection.

Water pressure: Max supply pressure before regulator: 125psi. Pressure at oven water inlet: 15-30 psi (install kit contains one 30psi regulator).

Drain size should be a minimum of 1" diameter and either a cup or floor drain with an 1" air gap.

ELECTRICAL

Power:	15.8-18.2 kw
Frequency:	60 Hz
Voltage (V):	AC 208/240v 3-phase
L1:	43 amps
L2:	42 amps
L3:	42 amps
Cable:	6/4 SOOW (supplied)
Plug:	NEMA 15-60P (supplied)
Breaker size:	60 amp (recommended)

WATER QUALITY SPECIFICATIONS

Free Chlorine:	< 0.1	ppm
Hardness:	30-70	ppm
Chloride:	< 30	ppm
Total Dissolved Solids:	50-125	ppm
Silica:	< 12	ppm
pH:	7.0 - 8.5	
Chloramine:	< 0.1	ppm
Alkalinity:	< 150	ppm (CaCO ₃)

AVAILABLE OPTIONS AND ACCESSORIES

- Table - standard height
- Floor stand / table for stacked ovens
- Proofer / holding cabinet
- Kit for mounting or stacking ovens
- Kit for overlapping tables
- Set of four (2 with brake) casters
- 18" x 26" stainless-steel grid
- Sous-vide cooking probe
- Detergent with rinse aid
- Spray kit with support and tube

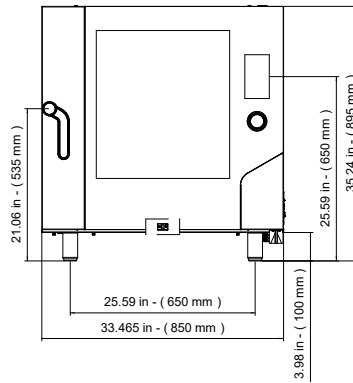
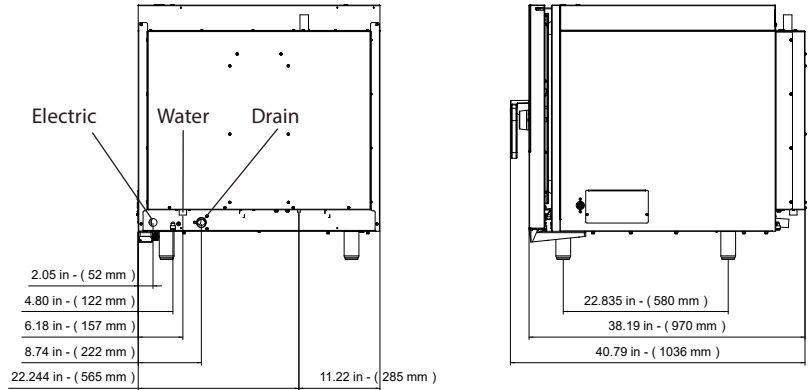

* Oven must be installed a minimum of 19.7" (500 mm) from any significant source of heat and/or grease (for example: fryers, burners, kettles, open flames, etc.)

Other surfaces must maintain a minimum of 3.94" (100mm) clearance.

We are not responsible for damage to the oven caused by any external heat source.

