

accurate dosing

BELDOS

FOR A BETTER FILLING

18 months warranty

Belmixing-bowl-lift 1050 Scale Depositor

Innovation in depositing!

Beldos offers a range of versatile volumetric stainless steel depositors with optional attachments for depositing, injection, layering and decoration. Beldos depositors will replace your pastry bag, spoon or a measuring cup and will become the most reliable, easy-to-use and intelligent equipment at your production!

1. Design features:

- depositor in combination with a weighing scale: install the required weight on the digital panel and start dosing
- max weight setting 50 kg; 100% accurate dosing
- dosing of products directly from a mixing bowl or a bucket
- quick clean-up for work with different products
- mounted on a mobile frame pneumatically adjustable in height for easy changing of mixing bowls and buckets
- 2 operation modes:
 - foot pedal
 - handgun switch

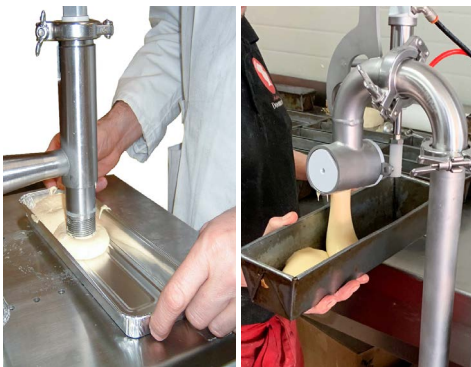

everyone can work with it

100% hygiene control



CLICK HERE TO WATCH THE MOVIE

time saving

quick change over from one product to another product

SPECIFICATIONS

Belmixing-bowl-lift 1050 Scale

*quick
cleaning*

ATTENTION! AIR COMPRESSOR IS REQUIRED!	
POWER	Air: 158 l/min at 30 deposits/min 7 Bar/102 PSI electricity: 100/240 VAC 1 ph - 50/60 HZ - 30 W
DEPOSIT RANGE	0.05 kg - 50 kg *
*data is approximate and depends on the product viscosity	



transfer speed:
10 - 65 l/min



particle size:
max Ø 2,5 cm



stainless steel

*fast, accurate,
clean & easy dosing*

adjust the speed



pneumatically adjustable in
height frame



control panel
with a
touch screen



product cylinder



d 50,8 mm
50-440 ml

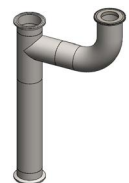

d 76,2 mm
200-1050 ml

*tool-free
assembly*

increased production efficiency

OPTIONS NOZZLES

save ingredients by correct dosing



rotary cut-off nozzle



vertical nozzle

 - 8°
cold products

+120° 
hot products

APPLICATIONS



DEPOSITING



ONLY pourable products!

depositing of cake batter, jam, jelly, fruit filling, cream, mousse, yoghurt, soup, sauce, etc.



sweet & savoury products

DIMENSIONS

Belmixing-bowl-lift
Scale 1050

*all stainless
steel construction*

*top quality
equipment*

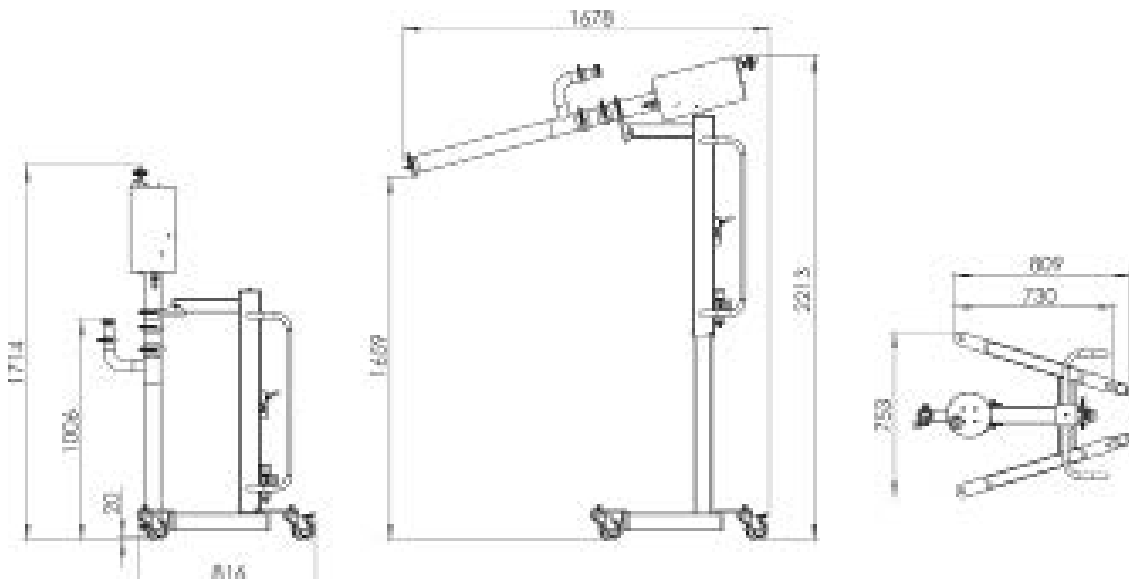

Beldos N.V.
Industrielaan 10 +32 3 646 40 48
2950 Kapellen info@beldos.be
Antwerp province www.beldos.com
Belgium

