



# Industrial Washers

Total Industrial Washing Solutions . . . . .	60
Costumized solutions to meet your every need . . . . .	61
NIEROS® WASHING SOLUTIONS . . . . .	63
NIEROS® SUSTAINABLE WASHING SOLUTIONS . . . . .	64
WASHING MACHINE STANDARD FEATURES . . . . .	65
NIEROS® TUNNEL WASHER STANDARD FEATURES. . . . .	66
NIEROS® WASHING MACHINE OPTIONS . . . . .	67
NIEROS® WASHING MACHINE OPTIONS . . . . .	68
NIEROS® ADDITIONAL WASHING EQUIPMENT . . . . .	69
Multipurpose Industrial Washers . . . . .	70
ABOUT NIEROS® MULTIPURPOSE WASHERS . . . . .	70
■ Crate, Bin and Pallet Washer CLT Multi . . . . .	70
■ Pallet Box and Stacking Container Washer CLT PB . . . . .	72
■ Pallet Box and Bin Washer CLK 800 . . . . .	74
■ Utensil Washer CLU . . . . .	76
■ Waste Bin Washer CLT WB . . . . .	77

## Item-Specific Industrial Washers . . . . 78

### ABOUT NIEROS® ITEM-SPECIFIC WASHERS . . . . 78

- Crate Washer CLT . . . . . 78
- IBC Washer CLT IBC . . . . . 80
- Pallet Washer CLT P . . . . . 82
- Bin Washer CLK 200 and CLK 300. . . . . 83
- Smoke Trolley Washer CLK ST . . . . . 84
- Mould Washer CLT MO . . . . . 85
- Poultry Crate Washer CLT PC . . . . . 86
- Automotive Battery Washer CLT ACU. . . . . 87
- Knife Basket Washer CLT B . . . . . 88
- Smoke Stick Washer CLS . . . . . 89

## Specialized Machines . . . . . 90

### ABOUT NIEROS® SPECIALIZED MACHINES . . . . . 90

- Sticker Remover CLT SR . . . . . 90
- Blow-off Machine ABT B . . . . . 92
- IBC Drying Tunnel ABT IBC . . . . . 93
- Vacuum-Packed Item Blow-off Tunnel ABT VP . . . . . 94

## Sanitizers . . . . . 95

### ABOUT NIEROS® SANITIZERS . . . . . 95

- Pack Sanitizing Machine CLT SA . . . . . 95

# Total Industrial Washing Solutions

Optimal hygiene is an absolute must; even more so in all food-processing enterprises and other industries where precision is imperative. When choosing the optimal industrial washing machine, high performance, efficiency and quality are vital.

NIEROS® fully comprehensive industrial washing machine range is the answer to a variety of businesses where superior washing performance is expected, going hand in hand with user-friendly operation and low operating costs.

With one of the NIEROS® washing machines, any dirty item can be washed quickly and thoroughly. Its multipurpose or specialized washing machines

are perfect for washing standardized items such as Euro crates, trays, moulds, boxes, racks, Euro-pallets, baskets and Eurobins while the fully customized machines meet clients' specific needs and requirements. With this in mind, NIEROS® washing units are geared to the latest technology and available in many different versions.

NIEROS® washing machines are not only cost-effective, owing to optimal water consumption and efficient energy use, but also comply with various standards and certifications such as ISO 9001, IFS, HACCP and NFS.

## BENEFITS

- Superior washing performance during the entire cleaning process
- User-friendly operation with adjustable washing parameters and easy access to spray nozzles and water tanks
- Water recycling
- Low operating and maintenance costs
- Easy cleaning and maintenance
- High-quality built-in parts
- Standardized for common items or fully customized to meet clients' specific needs and requirements
- In compliance with the highest quality requirements and HACCP, IFS and NSF International standards
- Fully comprehensive industrial washing solutions that perfectly fit the needs of your business

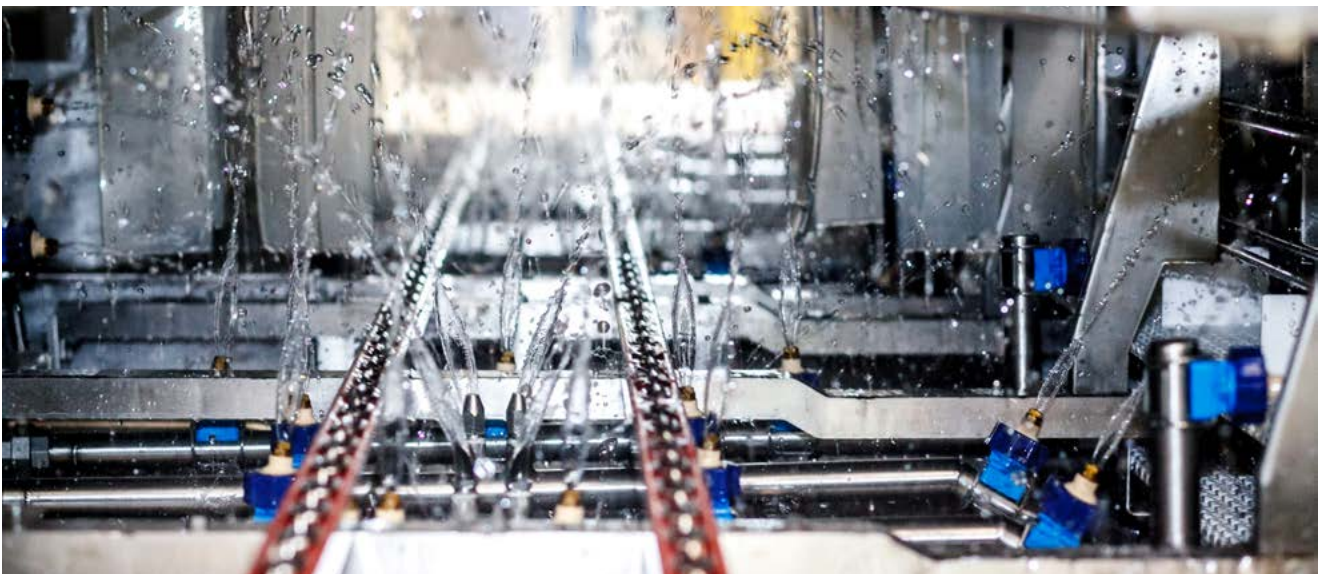

# Costumized solutions to meet your every need

■ No matter what type of industry you are operating in, NIEROS® has the right washing machine solution for you. Not only do we offer multipurpose and item-specific washing machines for cleaning standardized items, but we also provide fully customized solutions, designed and developed to your expectations and requirements to meet your every need and deliver superior washing performance.

NIEROS® washing machines can be comprehensively integrated into fully automatic conveyor systems and upgraded to their full

capacity for the items of wash to complete the entire washing-drying-sanitization cycle and pass all the cleaning phases with flying colours.

After a thorough wash and rinse, the various items of wash, e.g. empty Euro crates, Euro-pallets, trolleys, Eurobins and IBC containers, undergo initial drying before being transferred to a blow-off tunnel for a complete blow-off drying, which is followed by the sanitization phase in a sanitizing machine, from which the items are transported to the warehouse via a fully automated warehouse system.

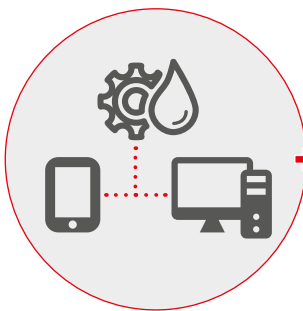

Digitally operated

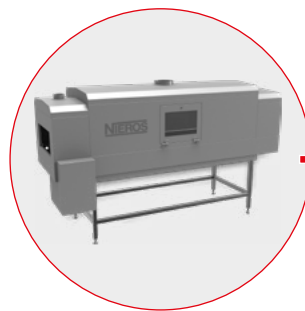

Sanitization tunnel

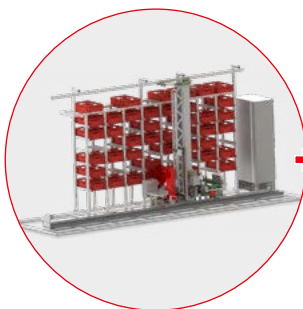

Automated warehouse system



Crate washer conveyor belt

### ITEMS OF WASH



Euro crate



Smoke trolley



IBC container



Eurobin

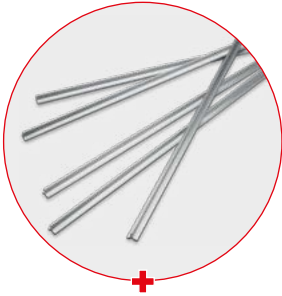

Smoke sticks



Automotive batteries

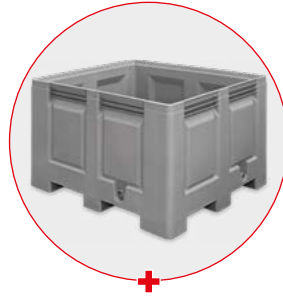

Euro pallet box



Waste bin



Vacuum-packed product

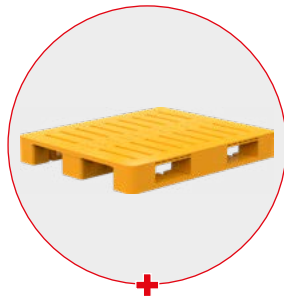

Euro-pallet



Stickers

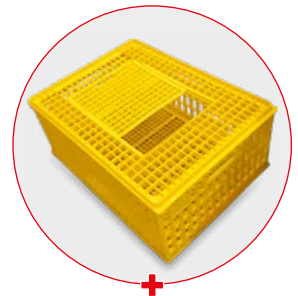

Poultry transport crate

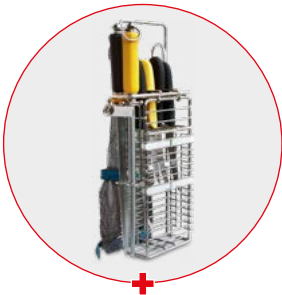

Knife basket



Utensil basket



Plastic barrel



Styrofoam box



Chocolate moulds



Cheese moulds



Trays

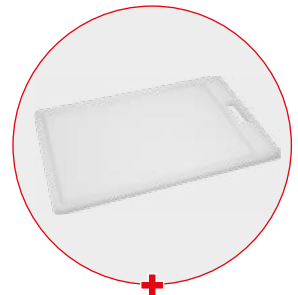

Cutting boards

# NIEROS® WASHING SOLUTIONS

“SUPERIOR WASHING EFFICIENCY  
for a Broad Range of Industries.



NIEROS® industrial washing solutions include a wide variety of products:

- **multipurpose washing machines**  
(tunnel and cabin options),
- **item-specific washing machines**  
(tunnel and cabin options),
- **specialized machines**  
(sticker removers, blow-off tunnels, drying machines),
- **sanitizers** and
- **fully customized washing solutions.**



# NIEROS® SUSTAINABLE WASHING SOLUTIONS

Sustainable development is placed at the heart of NIEROS® business as one of its core values. We realize long-term success is possible only when we think and act responsibly in everything we do. When developing and designing new solutions, we always bear in mind their impact on the environment.

Clean fresh water is an important and limited natural resource, which is why we put special effort into providing such washing solutions that save the amount of clean water used. As a result, our sustainable machine functions not only reduce water and energy consumption, but also guarantee long product lifetimes and time-cost optimization.



**Water recycling system** effectively reduces water consumption by reusing rinse water in other cleaning phases. The machine collects the rinse water to make it available either for a pre-washing or cleaning phase. As a result, the machine consumes significantly less freshwater in both these phases.

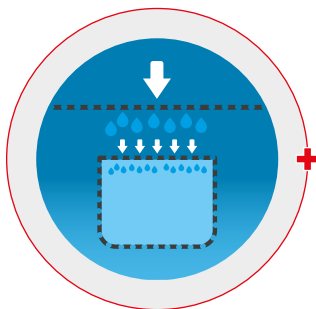

**Double filtering system** prolongs the pump's lifespan by ensuring that the double-filtered water flowing through the pump contains no dirt particles.

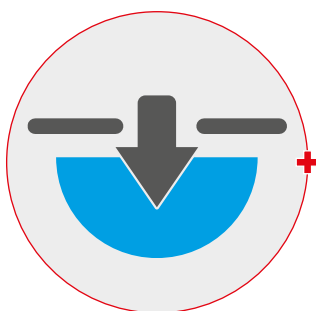

**Low water level protection** stops the machine in case of insufficient water level in the system, preventing damage to the pump and heating elements that could appear in case of dry operation.

# WASHING MACHINE STANDARD FEATURES



Washing and  
rinsing zone



Stainless steel  
DIN 1.4301 (AISI 304)

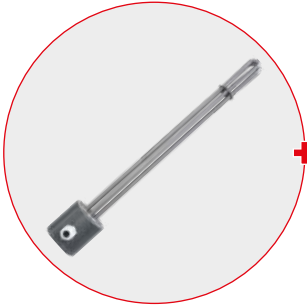

Electric  
water heating



Adjustable washing  
and rinsing parameters



Automatic  
detergent dispenser



Smooth surface finish

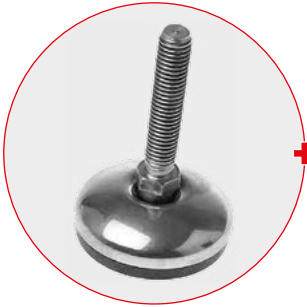

Height adjustable



IP65 protection

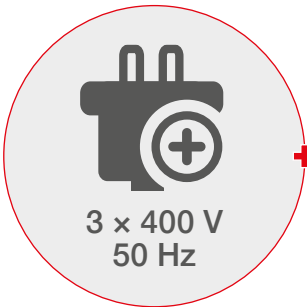

Electrical connection

3 x 400 V  
50 Hz



Safety beam  
(cabin washing machine)



# NIEROS® TUNNEL WASHER STANDARD FEATURES



**Object detection sensor in the rinsing zone** stops rinsing in the absence of items



**Stainless steel DIN 1.4301 (AISI 304) transport chain**



**Easily adjustable sideguards and hold-down attachments**

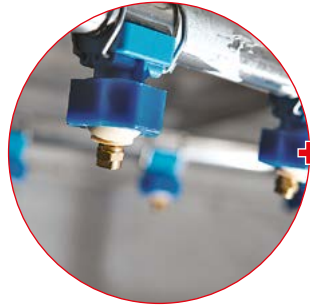

**Adjustable nozzles**



# NIEROS® WASHING MACHINE OPTIONS



Fully customized washing machine



DIN 1.4404 (AISI 316 L),  
DIN 1.4571 (AISI 316 Ti)  
or other chemically more resistant stainless steel



Adaptation to local electrical standards



Steam water heating



Additional electric flow heater  
(when the rinse water is too cold)

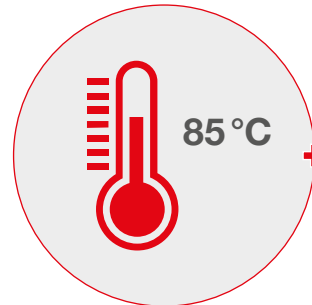

Sanitization with 85 °C hot water



Sanitizer dispenser

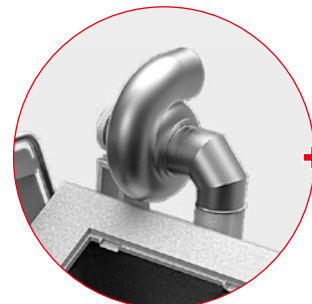

Vapour extraction fan

# NIEROS® WASHING MACHINE OPTIONS

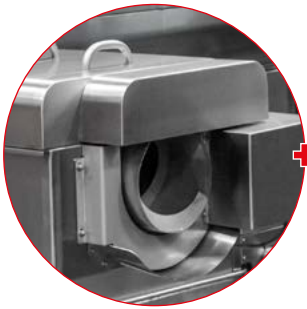

**Rotary drum filter for larger dirt particles**



**Belt filter to remove particles bigger than 2 mm<sup>2</sup>**

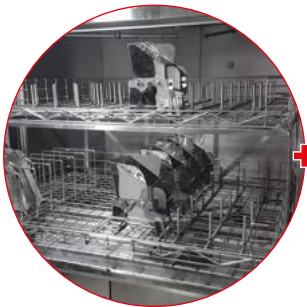

**Basket for utensils and small parts**



**Mesh conveyor belt**



**Left/right position of command keys**

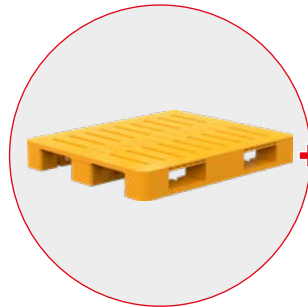

**Pallet washing (tunnel washers only)**



**Blow-off/drying**

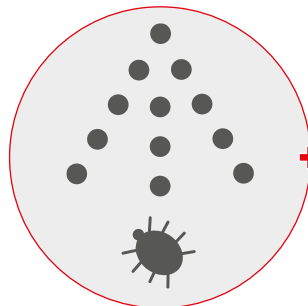

**Disinfection tunnel**



**Touchscreen control panel allowing remote access**

# NIEROS® ADDITIONAL WASHING EQUIPMENT

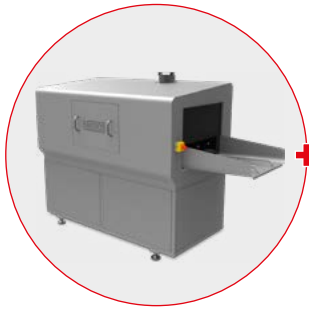

Blow-off tunnel



Sticker-removing module



Water-softening system

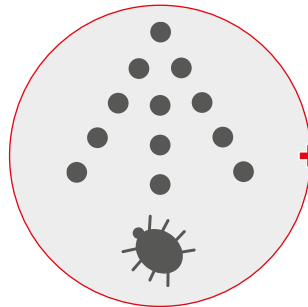

Disinfection tunnel



Exit conveyor



Stacking device

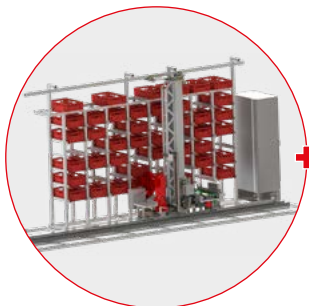

Clean crate storage with conveyors



One-man operation:  
Conveyor on top of  
the washer

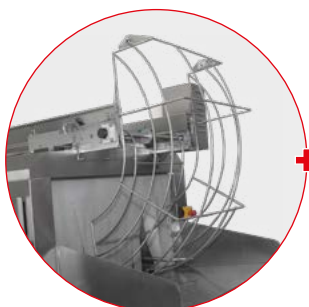

One-man operation:  
C-rail



Entry conveyor

# Multipurpose Industrial Washers

## ABOUT NIEROS® MULTIPURPOSE WASHERS

NIEROS® multipurpose washing machines are a convenient solution for any business with diverse items to be washed such as plastic crates, Eurobins, pallets, IBC containers and others. Built as multipurpose appliances, they are available in tunnel or cabin version.

### ■ Crate, Bin and Pallet Washer CLT Multi

■ NIEROS® Crate, Bin and Pallet Washing Machine CLT Multi effectively washes a variety of items such as 200- or 300-litre Eurobins, Euro crates, pallets, utensil baskets and different containers. The standard washing machine CLT Multi is equipped with an automatic swing lift for loading and unloading of Eurobins. CLT Multi can accommodate up to 1000 crates, 500 bins or 420 pallets per hour, depending on the model.

#### PRODUCT SPECIFICATIONS

- See NIEROS® Washing Machine Standard Features (p. 65)
- Washing and rinsing zone
- Tunnel washing machine
- Suitable for 200- or 300-litre Eurobins, Euro crates, pallets, utensil baskets and different containers
- Washing capacity of up to 1000 crates, 500 bins or 420 pallets per hour (depending on the model)
- Object detection sensor in the rinsing zone
- Stainless steel DIN 1.4301 (AISI 304) transport chain
- Easily adjustable sideguards and hold-down attachments
- Adjustable nozzles
- Easy and convenient access to spray nozzles and water tanks

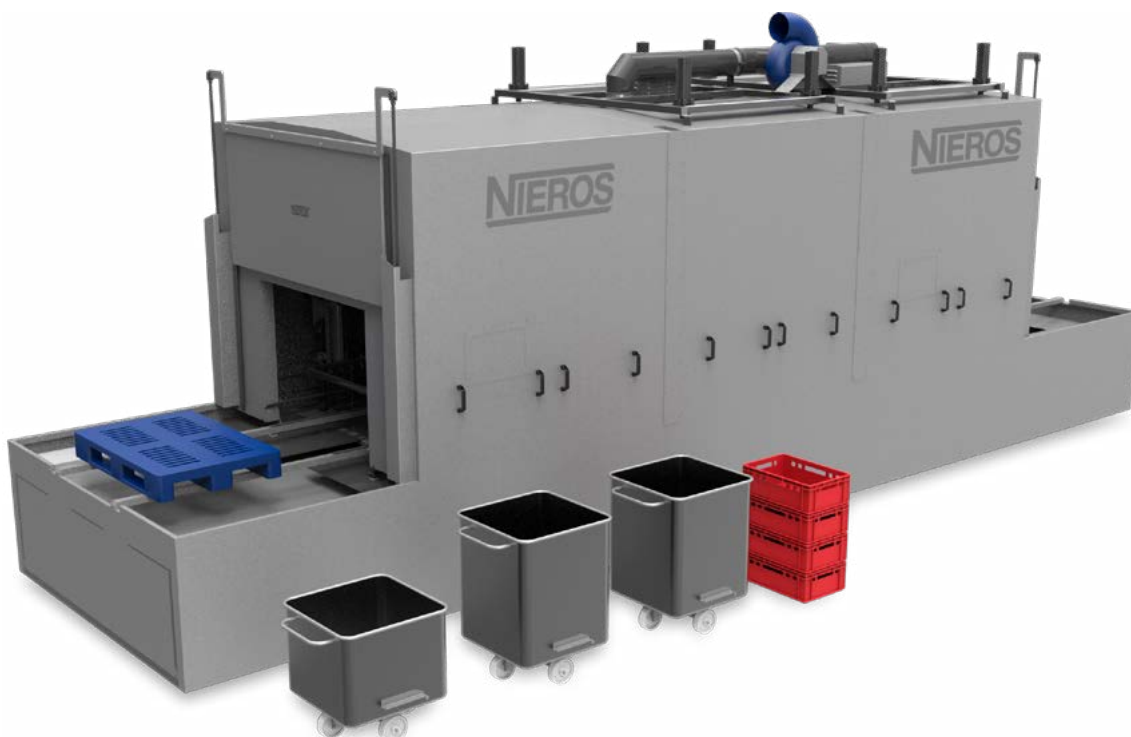

## ITEMS OF WASH

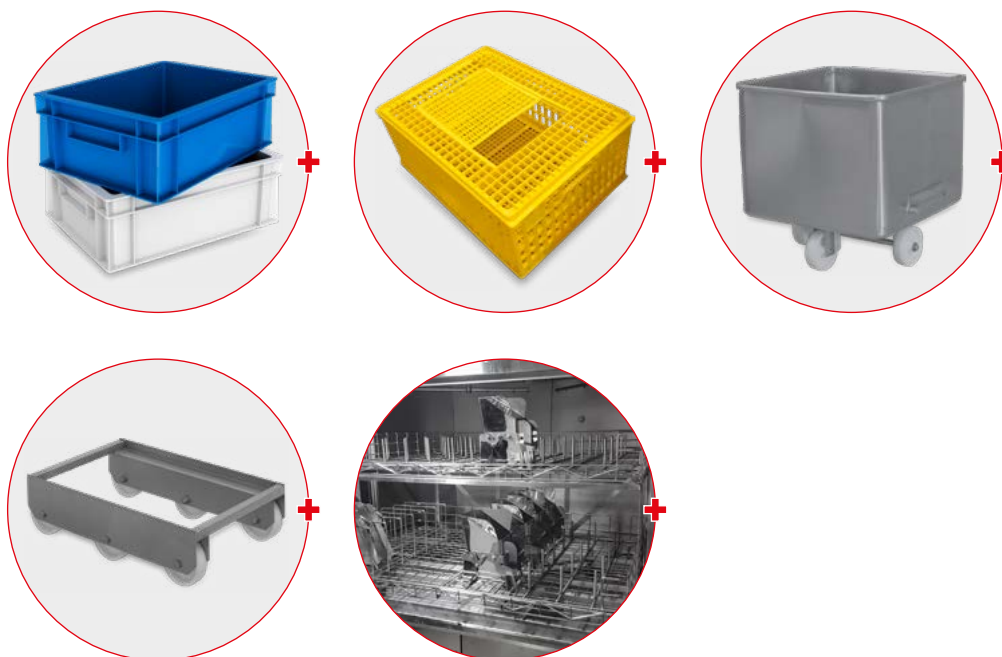

## PRODUCT OPTIONS AND ADDITIONAL EQUIPMENT

A variety of options and additional equipment is available with this model. For more information, please consult NIEROS® experts or distributors.

For a complete list of options and additional possibilities, see NIEROS® Washing Machine Options (pp. 67–68) and NIEROS® Additional Washing Equipment (p. 69).

Product model	CLT Multi 600	CLT Multi 800	CLT Multi 1000
Dimensions L x W x H	8 x 1.6 x 2.1 m	10.5 x 1.6 x 2.1 m	13 x 1.6 x 2.1 m
Items of wash	200- or 300-litre Eurobins, Euro crates, pallets, utensil baskets and containers		
Item's max. dimensions	Crates: max. 600 x 400 x 300 mm; bins: max. 300 L; pallet: max. width of 1000 mm		
	Max. washing capacity per hour		
Crate	600	800	1000
Bin	300	400	500
Pallet	250	330	420

## ■ Pallet Box and Stacking Container Washer CLT PB

- NIEROS® Pallet Box and Stacking Container Washing Machine CLT PB provides a thorough washing and drying of pallet boxes and their lids, pallets, stacking containers and other items of adequate dimensions. Depending on the model, CLT PB can accommodate up to 50 pallet boxes or similar items per hour with a size limit of 1250 × 1250 mm per item. The blow-off function is integrated into every CLT PB unit.

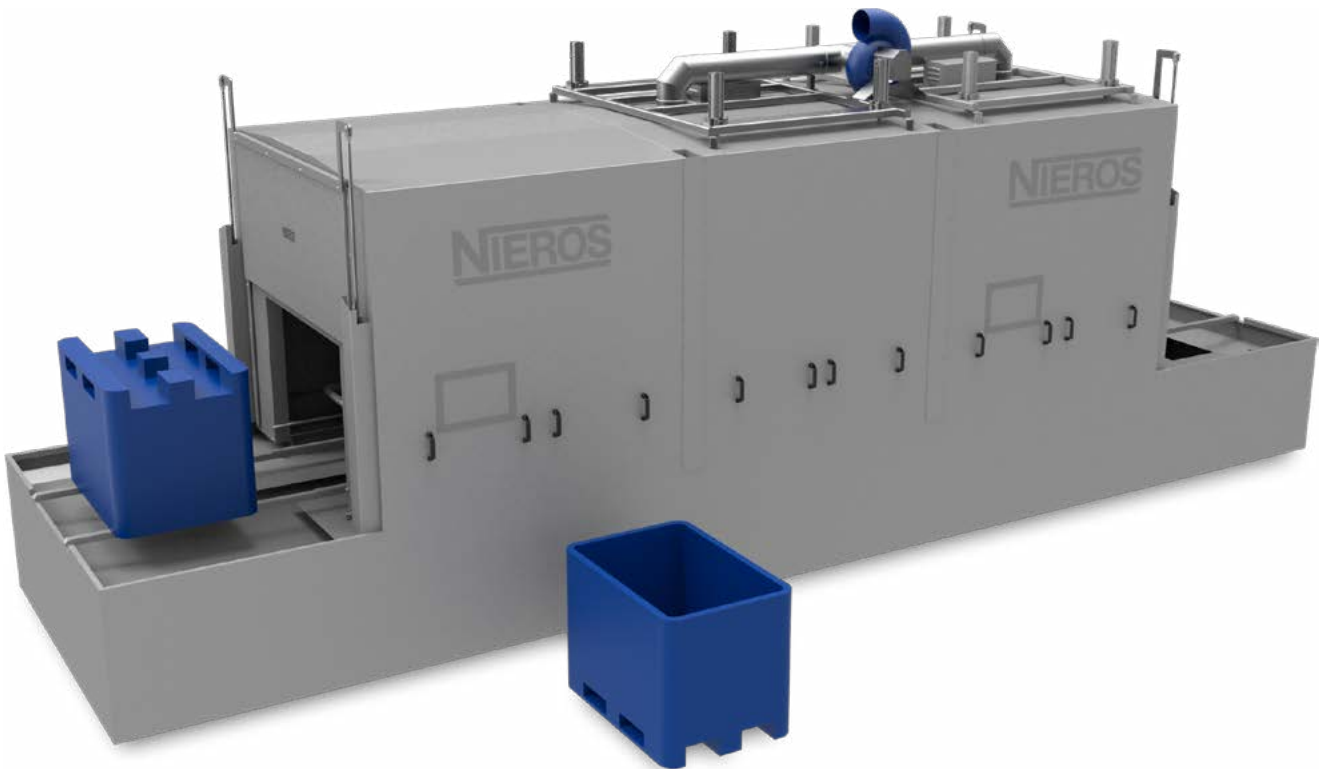

### PRODUCT SPECIFICATIONS

- See NIEROS® Washing Machine Standard Features (p. 65)
- Pre-washing, washing and rinsing zone
- Tunnel washing machine
- Suitable for pallet boxes and lids, pallets, stacking containers and other items of adequate dimensions
- Washing capacity of up to 50 items per hour (depending on the model)
- Blow-off function
- Object detection sensor in the rinsing zone
- Stainless steel DIN 1.4301 (AISI 304) transport chain
- Easy and convenient access to spray nozzles and water tanks

## ITEMS OF WASH

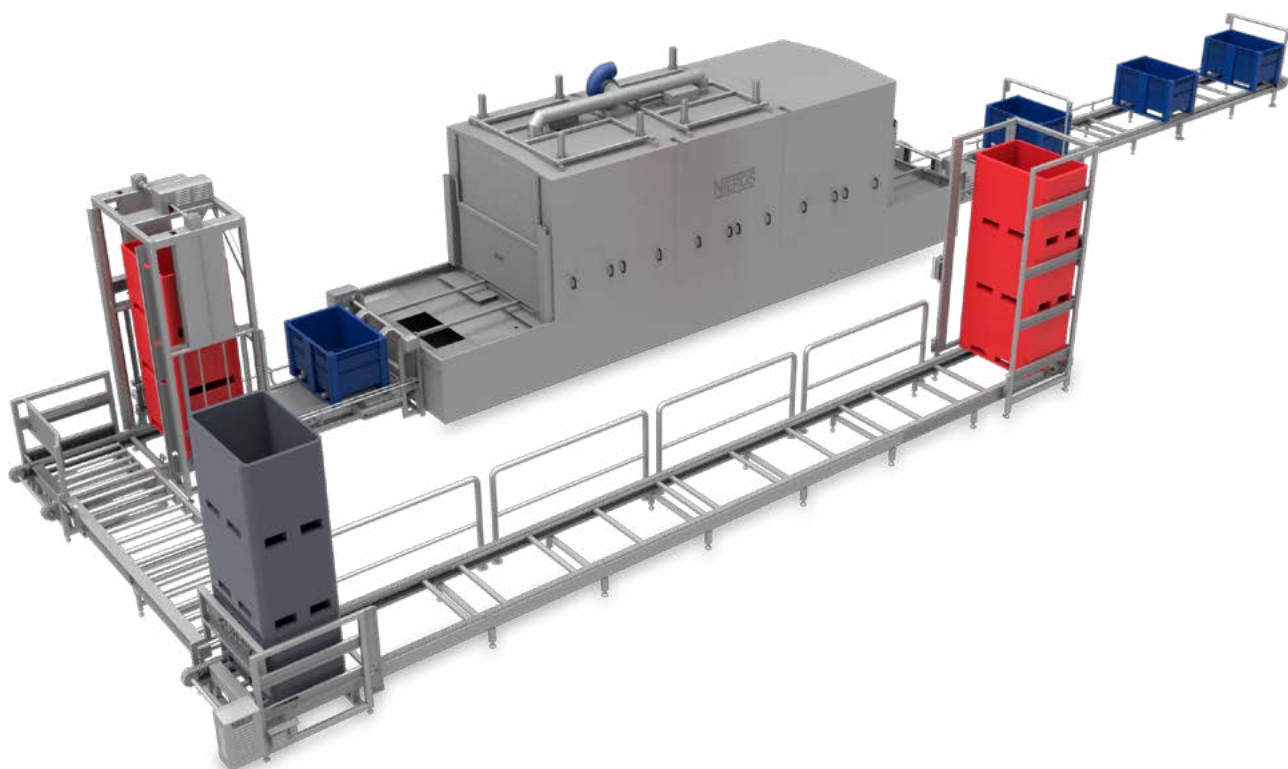
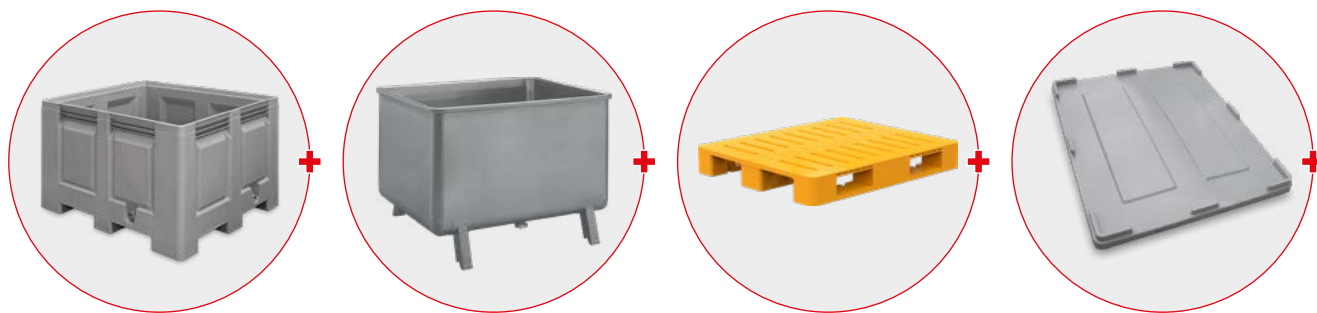

- The washer can be integrated into the conveying system with the items in stacks being loaded onto the conveyor, separated and turned around so that they can be thoroughly washed. It is a perfect solution for any industry in favour of automatic washing and drying of pallet boxes with or without lids, pallets and other similar items.

## PRODUCT OPTIONS AND ADDITIONAL EQUIPMENT

A variety of options and additional equipment is available with this model. For more information, please consult NIEROS® experts or distributors.

For a complete list of options and additional possibilities, see NIEROS® Washing Machine Options (pp. 67–68) and NIEROS® Additional Washing Equipment (p. 69).

Product model	CLT PB 15	CLT PB 30	CLT PB 50
Dimensions L x W x H	3.1 x 2.4 x 2.4 m	5 x 2.4 x 2.4 m	9 x 2.4 x 2.4 m
Items of wash	Pallet boxes and lids, pallets, stacking containers		
Item's max. dimensions	1250 x 1250 mm	1250 x 1250 mm	1250 x 1250 mm
Max. washing capacity per hour	15	30	50



## ■ Pallet Box and Bin Washer CLK 800

- NIEROS® Pallet Box and Bin Washing Machine CLK 800 not only washes and rinses, but also sanitizes pallet boxes, stacking containers and 200- or 300-litre bins (when upgraded) to provide superior hygiene in any production area following strict hygiene procedures. CLK 800 can accommodate up to 25 pallet boxes or similar items per hour with the maximum dimensions of 1260 × 1040 × 880 mm per item.



### PRODUCT SPECIFICATIONS

- See NIEROS® Washing Machine Standard Features (p. 65)
- Washing, rinsing and sanitizing
- Cabin washing machine
- Suitable for pallet boxes, stacking containers and 200- or 300-litre bins
- Washing capacity of up to 25 items per hour
- Automatized loading and unloading
- Safety guards in the loading and unloading area
- Safety light beams in the loading and unloading area

## ITEMS OF WASH

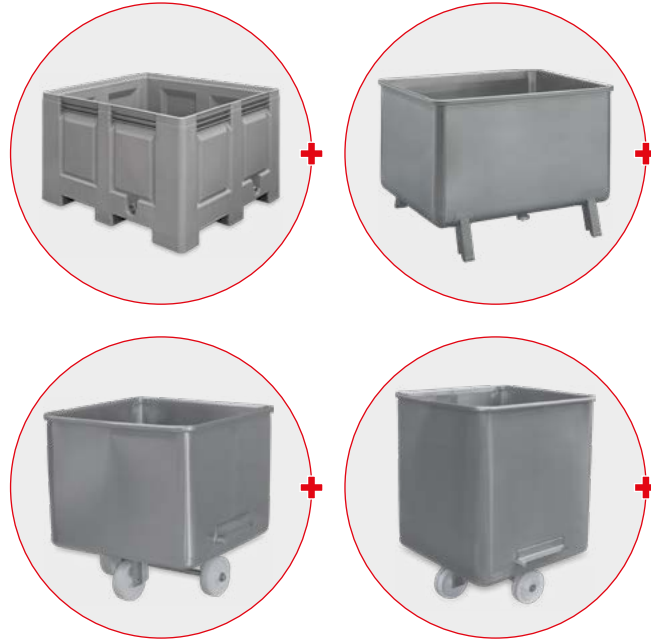

## PRODUCT OPTIONS AND ADDITIONAL EQUIPMENT

A variety of options and additional equipment is available with this model.

For more information, please consult NIEROS® experts or distributors.

For a complete list of options and additional possibilities, see NIEROS® Washing Machine Options (pp. 67–68) and NIEROS® Additional Washing Equipment (p. 69).

Product model	CLK 800
Dimensions L x W x H	3.8 x 2.5 x 3.3 m
Items of wash	Pallet boxes, stacking containers, 200- or 300-litre bins
Item's max. L x W x H	1260 x 1040 x 880 mm
Max. washing capacity per hour	25



# ■ Utensil Washer CLU



- NIEROS® Utensil Washer CLU is perfect for food, pharmaceutical and other industries where superior equipment hygiene is imperative. Enabling automatic cleaning and sanitization (sterilization) with hot water at 85 °C, it effectively washes knife baskets, machine parts (e.g. cutter knives), laboratory equipment, accessories, dishes, moulds, models and other utensils, Euro stacking containers and pallet boxes.

### PRODUCT SPECIFICATIONS

- Stainless steel DIN 1.4301 (AISI 304)
- Electric water heating
- Washing cycle of 2–4–6 minutes
- Hot water (85 °C) sanitization
- Stainless steel utensil basket
- Suitable for knife baskets, machine parts (e.g. cutter knives), laboratory equipment, accessories, dishes, moulds, models, other utensils, Euro stacking containers and pallet boxes.



+ Knife basket

### ITEMS OF WASH



### MODELS AND OPTIONS

- Detergent dispenser
- Rinse-aid dispenser
- Additional baskets
- Automatic disinfection
- Mobile
- Available in two-door version:
  - Option **G**: Lift door
  - Option **R**: Flap door that can be used as additional worktable

Product model	CLU 1000 G	CLU 1000 R
Dimensions L x W x H	1.1 x 1 x 1.9/2.5 m	1.1 x 1 x 1.9/2.2 m
Items of wash	Knife baskets, machine parts (e.g. cutter knives), laboratory equipment, accessories, dishes, moulds, models, other utensils, Euro stacking containers and pallet boxes	
Item's max. L x W x H	863 x 660 x 678 mm	863 x 660 x 692 mm
Basket (L x W x H)	850 x 640 x 648 mm	850 x 640 x 662 mm

# ■ Waste Bin Washer CLT WB



■ NIEROS® Waste Bin Washing Machine CLT WB is a perfect solution for thorough washing of waste bins, buckets, barrels and other comparable items. Depending on the model, which comes in a variety of options, the CLT WB washer can accommodate up to 500 items per hour with a size limit of 720 × 580 × 1070 mm per item.

## PRODUCT OPTIONS AND ADDITIONAL EQUIPMENT

A variety of options and additional equipment is available with this model. For more information, please consult NIEROS® experts or distributors.

For a complete list of options and additional possibilities, see NIEROS® Washing Machine Options (pp. 67–68) and NIEROS® Additional Washing Equipment (p. 69).

## PRODUCT SPECIFICATIONS

- See NIEROS® Washing Machine Standard Features (p. 65)
- Washing and rinsing zone
- Tunnel washing machine
- Suitable for waste bins, buckets and barrels with lids and other comparable items
- Washing capacity of up to 500 items per hour
- Special washing lane for the lids guarantees a thorough cleaning
- Object detection sensor in the rinsing zone
- Stainless steel DIN 1.4301 (AISI 304) transport chain
- Easily adjustable sideguards and hold-down attachments
- Adjustable nozzles
- Easy and convenient access to spray nozzles and water tanks.

## ITEMS OF WASH



Product model	CLT WB 200	CLT WB 300	CLT WB 500
Dimensions L × W × H	7.1 × 1.6 × 3 m	8.4 × 1.6 × 3 m	14 × 1.6 × 3 m
Items of wash	Waste bins, buckets, barrels		
Item's max. L × W × H	720 × 580 × 1070 mm		
Max. washing capacity per hour	200	300	500

# Item-Specific Industrial Washers

## ABOUT NIEROS® ITEM-SPECIFIC WASHERS

Available in tunnel or cabin version, NIEROS® item-specific washing machines are a first-class solution for any business with specific items of similar shape, size and material to be washed.

### ■ Crate Washer CLT



- NIEROS® Crate Washing Machine CLT is a compact industrial washer for a thorough cleaning of Euro crates or crates with similar characteristics and dimensions, utensil baskets and pallets. With the efficient washing and rinsing zone, it guarantees superior cleaning results.

#### PRODUCT SPECIFICATIONS

- See NIEROS® Washing Machine Standard Features (p. 65)
- Washing and rinsing zone
- Tunnel washing machine
- Suitable for Euro crates, other crates of similar dimensions, trays, utensil baskets and pallets
- Washing capacity of up to 3000 items per hour (depending on the model)
- Object detection sensor in the rinsing zone
- Stainless steel DIN 1.4301 (AISI 304) transport chain
- Easily adjustable sideguards and hold-down attachments
- Adjustable nozzles
- Easy and convenient access to spray nozzles and water tanks
- Mobile wheels (model CLT 250 only)

## ITEMS OF WASH



## PRODUCT OPTIONS AND ADDITIONAL EQUIPMENT

A variety of options and additional equipment is available with this model.

For more information, please consult NIEROS® experts or distributors.

For a complete list of options and additional possibilities, see NIEROS® Washing Machine Options (pp. 67–68) and NIEROS® Additional Washing Equipment (p. 69).

Product model	CLT 100	CLT 250
Dimensions L x W x H	2.6 x 0.9 x 1.6 m	3.1 x 0.9 x 1.6 m
Items of wash	Euro crates, trays, utensil baskets	
Item's max. L x W x H	600 x 400 x 300 mm	600 x 400 x 300 mm
Max. washing capacity of Euro crates per hour	100	250

Product model	CLT 400	CLT 600	CLT 800
Dimensions L x W x H	3.9 x 1.1 x 1.6 m	5.4 x 1.1 x 1.6 m	6.4 x 1.1 x 1.6 m
Items of wash	Euro crates, pallets*, trays, utensil baskets		
Item's max. L x W x H	600 x 400 x 300 mm	600 x 400 x 300 mm	600 x 400 x 300 mm
Max. washing capacity of Euro crates per hour	400	600	800

Product model	CLT 1000	CLT 1200	CLT 1500
Dimensions L x W x H	7.9 x 1.1 x 1.6 m	6.0 x 1.5 x 1.6 m	6.5 x 1.5 x 1.6 m
Items of wash	Euro crates, pallets*, trays, utensil baskets		
Item's max. L x W x H	600 x 600 x 300 mm	600 x 1000 x 300 mm	1000 x 400 x 300 mm
Max. washing capacity of Euro crates per hour	1000	1200	1500

\* optional

## ■ IBC Washer CLT IBC

- NIEROS® IBC Washing Machine CLT IBC is specially designed to provide superior washing of stainless steel intermediate bulk containers (i.e. IBC containers) with or without a cover. The standard CLT IBC can accommodate up to 60 IBC containers per hour with the maximum container dimensions of 1160 × 1380 × 1680 mm.

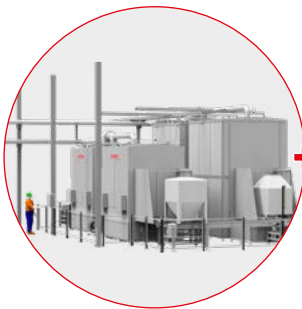

■ IBC Drying Tunnel ABT IBC  
(p. 93)

### PRODUCT SPECIFICATIONS

- See NIEROS® Washing Machine Standard Features (p. 65)
- Washing and rinsing zone
- Tunnel washing machine
- Suitable for IBC containers
- Washing capacity of up to 60 IBC containers per hour
- Stainless steel DIN 1.4301 (AISI 304) transport chain
- Highly sophisticated washing system

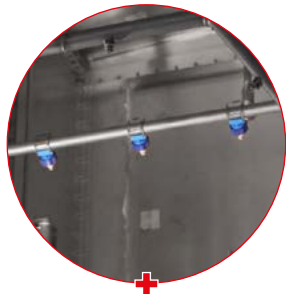

**Adjustable nozzles for IBC container exterior washing**



**Blow-off nozzles for IBC container exterior drying**

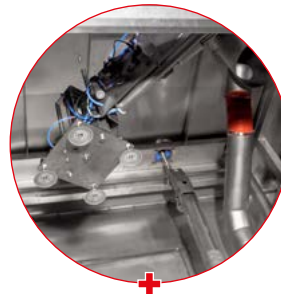

**Lid-removing robotic arm**

### ITEMS OF WASH

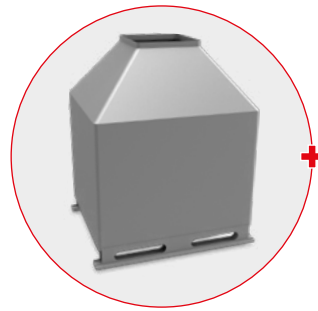

### PRODUCT OPTIONS AND ADDITIONAL EQUIPMENT

A variety of options and additional equipment is available with this model. For more information, please consult NIEROS® experts or distributors.

For a complete list of options and additional possibilities, see NIEROS® Washing Machine Options (pp. 67–68) and NIEROS® Additional Washing Equipment (p. 69).

Product model	CLT IBC 30	CLT IBC 60
Dimensions L x W x H	3.5 x 3.0 x 5.1 m	7.0 x 3.0 x 5.1 m
Items of wash	Intermediate bulk containers (IBC containers)	
Item's max. L x W x H	1160 x 1380 x 1680 mm	1160 x 1380 x 1680 mm
Max. washing capacity per hour	30	60



# ■ Pallet Washer CLT P



■ NIEROS® Pallet Washing Machine CLT P effectively washes plastic and metal pallets (S/S, aluminium or other material), trays, layer pads and other comparable items, which can be loaded into the washing machine as follows: manually one at a time, in stacks, or on a conveyor. The standard CLT P can accommodate up to 240 items per hour with a maximum size of 1000 × 1200 mm per item.

### PRODUCT SPECIFICATIONS

- See NIEROS® Washing Machine Standard Features (p. 65)
- Washing and rinsing zone
- Tunnel washing machine
- Suitable for pallets, trays, layer pads and similar items
- Washing capacity of up to 240 items per hour (depending on the model)
- Brushes for thorough pallet surface cleaning
- Object detection sensor in the rinsing zone
- Stainless steel DIN 1.4301 (AISI 304) transport chain
- Easily adjustable sideguards
- Easy and convenient access to water tanks

### ITEMS OF WASH

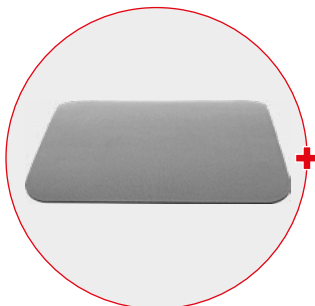
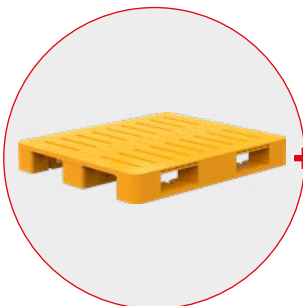

Brushes

Product model	CLT P 120	CLT P 180	CLT P 240
Dimensions L × W × H	4.8 × 1.2 × 2.1 m	5.3 × 1.2 × 2.1 m	5.8 × 1.2 × 2.1 m
Items of wash	Pallets (S/S, aluminium or other material), trays, layer pads and similar items		
Item's max. L × W × H	1000 × 1200 mm		
Max. washing capacity per hour	120	180	240

# ■ Bin Washer CLK 200 and CLK 300



- NIEROS® Bin Washing Machine CLK 200 and CLK 300 are perfect for washing 200- or 300-litre Eurobins, made as per DIN 9797 or USDA standard version. As a cabin version, CLK 200 and CLK 300 thoroughly wash both the bins and their wheels, accommodating up to 30 bins per hour.

## PRODUCT SPECIFICATIONS

- See NIEROS® Washing Machine Standard Features (p. 65)
- Washing and rinsing zone
- Cabin washing machine
- Suitable for 200- or 300-litre Eurobins
- Washing capacity of up to 30 bins per hour
- Automatized loading and unloading
- Safety guards in the loading and unloading area
- Safety light beams in the loading and unloading area
- Easy and convenient access to spray nozzles and water tanks

## PRODUCT OPTIONS AND ADDITIONAL EQUIPMENT

A variety of options and additional equipment is available with this model. For more information, please consult NIEROS® experts or distributors.

For a complete list of options and additional possibilities, see NIEROS® Washing Machine Options (pp. 67–68) and NIEROS® Additional Washing Equipment (p. 69).

## ITEMS OF WASH

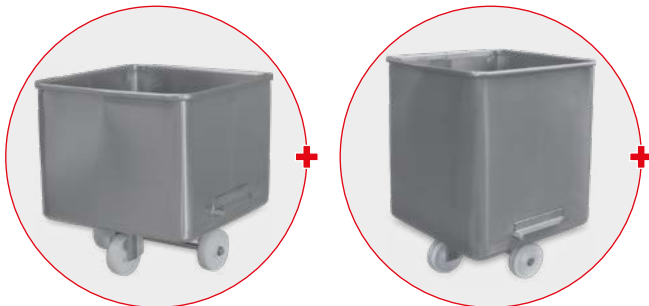

Product model	CLK 200	CLK 300
Dimensions L x W x H	3.8 x 1.9 x 2.6 m	4.0 x 1.9 x 2.9 m
Items of wash	200-litre Eurobins	300-litre Eurobins
Item's max. L x W x H	690 x 680 x 700 mm	730 x 680 x 950 mm
Max. washing capacity per hour	30	30

# Smoke Trolley Washer CLK ST



- NIEROS® Smoke Trolley Washing Machine CLK ST is a perfect solution for an effective and thorough wash of smoke trolleys. CLK ST can accommodate up to 25 smoke trolleys per hour with a size limit of 1000 × 1025 × 2000 mm per trolley.

## PRODUCT SPECIFICATIONS

- See NIEROS® Washing Machine Standard Features (p. 65)
- Foaming, washing and rinsing zone
- Cabin washing machine
- Suitable for smoke trolleys
- Washing capacity of up to 25 smoke trolleys per hour
- Built-in version highly recommended
- Safety guards in the loading and unloading area
- Safety light beams in the loading and unloading area
- Easy and convenient access to water tanks

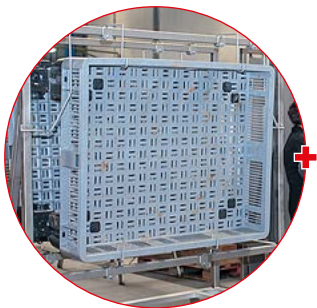

Pallet washing



Smoke Trolley Tunnel Washer CLK ST 25

## ITEMS OF WASH



## PRODUCT OPTIONS AND ADDITIONAL EQUIPMENT

A variety of options and additional equipment is available with this model. For more information, please consult NIEROS® experts or distributors.

For a complete list of options and additional possibilities, see NIEROS® Washing Machine Options (pp. 67–68) and NIEROS® Additional Washing Equipment (p. 69).

Product model	CLK ST 25
Dimensions L × W × H	3.8 × 2 × 3.1 m
Items of wash	Smoke trolleys
Item's of wash max. L × W × H	1000 × 1025 × 2000 mm
Max. washing capacity per hour	25

# ■ Mould Washer CLT MO



- NIEROS® Mould Washing Machine CLT MO effectively washes various types of moulds (for cheese, chocolate, patisserie and comparable products), trays and cutting boards. By removing all the residue and grease, it leaves the items perfectly clean and ready for reuse. The standard CLT MO can accommodate up to 600 items per hour with a 1052 × 460 × 90 mm size limit per item. Mould Washer CLT MO can be combined with the conveyor system and blow-off module.

## PRODUCT SPECIFICATIONS

- See NIEROS® Washing Machine Standard Features (p. 65)
- Washing and rinsing zone
- Tunnel washing machine
- Suitable for moulds, trays and cutting boards
- Washing capacity of up to 600 items per hour (depending on the model)
- Object detection sensor in the rinsing zone
- Stainless steel DIN 1.4301 (AISI 304) transport chain
- Easily adjustable sideguards and hold-down attachments
- Adjustable nozzles
- Easy and convenient access to spray nozzles and water tanks

## PRODUCT OPTIONS AND ADDITIONAL EQUIPMENT

A variety of options and additional equipment is available with this model. For more information, please consult NIEROS® experts or distributors.

For a complete list of options and additional possibilities, see NIEROS® Washing Machine Options (pp. 67–68) and NIEROS® Additional Washing Equipment (p. 69).

## ITEMS OF WASH



Product model	CLT MO 250	CLT MO 400	CLT MO 600
Dimensions L x W x H	3.9 x 1.1 x 1.4 m	8.3 x 1.1 x 1.4 m	10 x 1.1 x 1.4 m
Items of wash	Moulds, trays and cutting boards		
Item's max. L x W x H	1050 x 460 x 90 mm	1050 x 460 x 90 mm	1050 x 460 x 90 mm
Max. washing capacity per hour	250	400	600

# ■ Poultry Crate Washer CLT PC



- NIEROS® Poultry Crate Washing Machine CLT PC is designed specifically for a thorough cleaning of multisize poultry transport crates. The standard CLT PC can accommodate up to 800 poultry crates per hour with a maximum crate size of 1000 × 600 × 420 mm. The washer can be used as a module in the conveying system handling live poultry to meet high hygienic standards of poultry farming.

### PRODUCT SPECIFICATIONS

- See NIEROS® Washing Machine Standard Features (p. 65)
- Washing and rinsing zone
- Tunnel washing machine
- Suitable for poultry transport crates
- Washing capacity of up to 800 poultry crates per hour (depending on the model)
- Object detection sensor in the rinsing zone
- Stainless steel DIN 1.4301 (AISI 304) transport chain
- Easily adjustable sideguards and hold-down attachments
- Adjustable nozzles
- Easy and convenient access to spray nozzles and water tanks

### ITEMS OF WASH

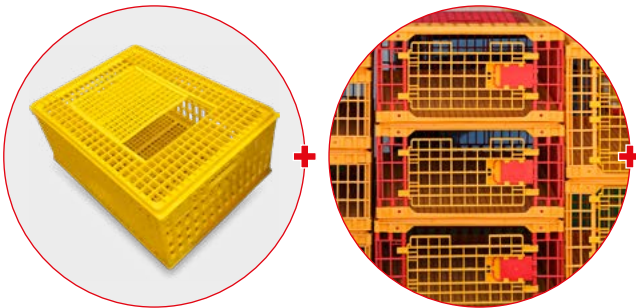

### PRODUCT OPTIONS AND ADDITIONAL EQUIPMENT

A variety of options and additional equipment is available with this model. For more information, please consult NIEROS® experts or distributors.

For a complete list of options and additional possibilities, see NIEROS® Washing Machine Options (pp. 67–68) and NIEROS® Additional Washing Equipment (p. 69).

Product model	CLT PC 150	CLT PC 400	CLT PC 600	CLT PC 800
Dimensions L × W × H	3.1 × 1.1 × 1.6 m	4.1 × 1.1 × 1.6 m	4.5 × 1.1 × 1.6 m	5.1 × 1.5 × 1.6 m
Items of wash	Poultry transport crates			
Item's max. L × W × H	1000 × 600 × 420 mm	1000 × 600 × 420 mm	1000 × 600 × 420 mm	1000 × 600 × 420 mm
Max. washing capacity per hour	150	400	600	800

# ■ Automotive Battery Washer CLT ACU



■ NIEROS® Automotive Battery Washing Machine CLT ACU is a compact industrial tunnel washer, effectively washing various automotive batteries of similar characteristics and dimensions. CLT ACU can accommodate up to 1000 automotive batteries per hour, depending on the model.

## PRODUCT SPECIFICATIONS

- See NIEROS® Washing Machine Standard Features (p. 65)
- Washing and rinsing zone
- Tunnel washing machine
- Suitable for automotive batteries
- Washing capacity of up to 1000 automotive batteries per hour (depending on the model)
- Object detection sensor in the rinsing zone
- Stainless steel DIN 1.4301 (AISI 304) transport chain
- Easily adjustable sideguards
- Adjustable nozzles
- Easy and convenient access to spray nozzles and water tanks

## ITEMS OF WASH



## PRODUCT OPTIONS AND ADDITIONAL EQUIPMENT

A variety of options and additional equipment is available with this model. For more information, please consult NIEROS® experts or distributors. For a complete list of options and additional possibilities, see NIEROS® Washing Machine Options (pp. 67–68) and NIEROS® Additional Washing Equipment (p. 69).

Product model	CLT ACU 250	CLT ACU 400	CLT ACU 600	CLT ACU 800	CLT ACU 1000
Dimensions L x W x H	3.1 x 1.1 x 1.6 m	3.9 x 1.1 x 1.6 m	4.1 x 1.1 x 1.6 m	4.5 x 1.1 x 1.6 m	4.5 x 1.1 x 1.6 m
Items of wash	Automotive batteries				
Item's max. L x W x H	600 x 400 x 300 mm	600 x 400 x 300 mm	600 x 400 x 300 mm	600 x 400 x 300 mm	600 x 400 x 300 mm
Max. washing capacity per hour	250	400	600	800	1000

# ■ Knife Basket Washer CLT B



- NIEROS® Knife Basket Washing Machine CLT B effectively washes knife baskets, trays and cutting boards, and other items of adequate dimensions. The standard CLT B can accommodate up to 2000 knife baskets per hour with a maximum basket size of 360 × 115 × 475 mm. Apart from being thoroughly washed, all the items are also effectively sanitized with hot water at 85 °C.

## PRODUCT SPECIFICATIONS

- See NIEROS® Washing Machine Standard Features (p. 65)
- Washing, rinsing and sanitizing with hot water (85 °C)
- Tunnel washing machine
- Suitable for knife baskets, trays and cutting boards, and other items of adequate dimensions
- Washing capacity of up to 2000 knife baskets per hour (depending on the model)
- Object detection sensor in the rinsing zone
- Easily adjustable sideguards
- Easy and convenient access to spray nozzles and water tanks
- Mobile wheels (optional)

## PRODUCT OPTIONS AND ADDITIONAL EQUIPMENT

A variety of options and additional equipment is available with this model. For more information, please consult NIEROS® experts or distributors.

For a complete list of options and additional possibilities, see NIEROS® Washing Machine Options (pp. 67–68) and NIEROS® Additional Washing Equipment (p. 69).

## ITEMS OF WASH

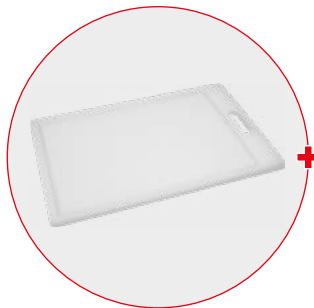
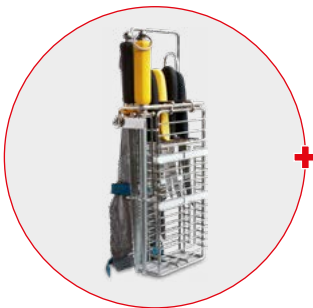

Product model	CLT B 1500	CLT B 1800	CLT B 2000
Dimensions L x W x H	3.7 x 1 x 1.7 m	4.1 x 1 x 1.7 m	4.5 x 1 x 1.7 m
Items of wash	Knife baskets, trays and cutting boards		
Item's max. L x W x H	360 x 115 x 475 mm		
Max. washing capacity per hour	1500	1800	2000

# ■ Smoke Stick Washer CLS



- NIEROS® Smoke Stick Washing Machine CLS effectively washes aluminium and stainless steel smoke sticks of different shapes and lengths (up to 1100 mm) by removing sticky and greasy resin residues in a specially designed drum. Depending on the model, CLS Washer can accommodate up to 180 smoke sticks per hour with a maximum length of 1000 mm per smoke stick.

## PRODUCT SPECIFICATIONS

- Washing
- Suitable for smoke sticks
- Rotating drum container
- Manual detergent dosage
- Washing capacity of up to 180 smoke sticks per hour (depending on the model)
- Larger drum to wash sticks of 1100 mm or more (optional)

## ITEMS OF WASH

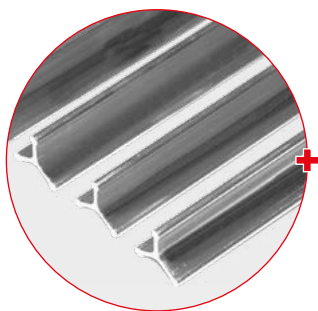

## PRODUCT OPTIONS AND ADDITIONAL EQUIPMENT

A variety of options and additional equipment is available with this model. For more information, please consult NIEROS® experts or distributors.

For a complete list of options and additional possibilities, see NIEROS® Washing Machine Options (pp. 67–68) and NIEROS® Additional Washing Equipment (p. 69).

Product model	CLS 100	CLS 250
Dimensions L x W x H	1.5 x 0.4 x 1.2 m	1.5 x 0.7 x 1.4 m
Items of wash	Smoke sticks	
Item's max. length	1000 mm	1000 mm
Max. washing capacity per hour	120	180



# Specialized Machines

## ABOUT NIEROS® SPECIALIZED MACHINES

NIEROS® specialized machines are a first-class solution for any industrial washing process aiming towards superior performance. Combined with other NIEROS® washing machines, they are indispensable in a wide array of industries such as bakery, dairy, fish and seafood, fruit and vegetable, meat, chemical and other sectors, functioning either as an independent or a modular unit of a broader washing system.

### ■ Sticker Remover CLT SR

- NIEROS® Sticker Remover CLT SR is designed to remove stickers from crates quickly and efficiently. Its powerful pump provides enough pressure to remove over 90% of all stickers without using any special chemicals. For optimal results, two high-pressure nozzles of 150 bar are placed on the side of the machine.

As a modular unit, the CLT SR Sticker Remover can be integrated into any NIEROS® tunnel washing machine designed for the same items of wash, or can, as such, function independently as a self-standing unit. It accommodates up to 1500 crates per hour with a maximum crate size of 600 × 400 × 300 mm.



## PRODUCT SPECIFICATIONS

- Tunnel washing machine
- Suitable for removing stickers from Euro crates and other crates of similar dimensions
- Washing capacity of up to 1500 crates per hour
- Stainless steel DIN 1.4301 (AISI 304)
- Adjustable washing parameters
- Water recycling system
- Double filtering system
- Low water protection system
- Stainless steel DIN 1.4301 (AISI 304) transport chain
- Easily adjustable sideguards and hold-down attachments
- Easy and convenient access to spray nozzles and water tanks
- Smooth surface finish
- Height adjustable
- IP65 protection
- Electrical connection of 3 × 400 V, 50 Hz
- Fully customized (optional)

## ITEMS OF WASH



## PRODUCT OPTIONS AND ADDITIONAL EQUIPMENT

A variety of options and additional equipment is available with this model. For more information, please consult NIEROS® experts or distributors.

For a complete list of options and additional possibilities, see NIEROS® Washing Machine Options (pp. 67–68) and NIEROS® Additional Washing Equipment (p. 69).

Product model	CLT SR 250
Dimensions L × W × H	2.7 × 1.4 × 1.8 m
Items of wash	Stickers (on Euro and other plastic crates)
Item's max. L × W × H	600 × 400 × 300 mm
Max. washing capacity per hour	250

# ■ Blow-off Machine ABT B



■ NIEROS® Blow-off Machine ABT B effectively complements any industrial washing process. The unit removes residual water from the items washed by means of a special airflow system. For optimal results, the items should be rinsed with hot water at approximately 85 °C beforehand. In case more than 90% of residual water is to be removed, a rinse-aid upgrade is necessary. The standard ABT B Blow-off Machine can accommodate up to 1500 crates (of max. 600 × 400 × 300 mm in size) per hour or the number of pallet boxes as per the CLT Washer capacity.

As a modular unit, Blow-off Machine ABT B can be integrated with any NIEROS® tunnel washing machine designed for the same items of wash to form a comprehensive washing system, or it can work independently as a self-standing unit.

## PRODUCT SPECIFICATIONS

- Stainless steel DIN 1.4301 (AISI 304)
- Adjustable drying parameters
- Smooth surface finish
- Height adjustable
- Integrated or separate unit
- Low operating and maintenance costs
- Fully customized (optional)
- IP65 protection
- Electrical connection of 3 × 400 V, 50 Hz

Product model	ABT B 250	ABT B 400	ABT B PB 15
Dimensions L × W × H	2,5 × 0,85 × 1,7 m	3,2 × 1,1 × 1,7 m	4.5 × 1 × 1.7 m
Items of drying	Crates, pallet boxes		
Item's max. L × W × H	600 × 400 × 300 mm (crates), pallet box: max. width 1000 mm		
Max. drying capacity per hour	250 crates	400 crates	15 pallet boxes

Product model	ABT B PB 30	ABT B PB 50
Dimensions L × W × H	4.1 × 1 × 1.7 m	4.5 × 1 × 1.7 m
Items of drying	Crates, pallet boxes	
Item's max. L × W × H	600 × 400 × 300 mm (crates), pallet box: max. width 1000 mm	
Max. drying capacity per hour	30 pallet boxes	50 pallet boxes

# ■ IBC Drying Tunnel ABT IBC



- NIEROS® IBC Drying Tunnel ABT IBC is designed to completely dry any metal item (e.g. stainless steel IBCs, bins and other items) after a thorough wash. Accelerated air, blowing through a sophisticated air-nozzle system, effectively removes residual water from the items. For optimal results, items should be rinsed with hot water at a temperature of approximately 85 °C beforehand. Depending on the model, the tunnel can accommodate up to 50 items of drying per hour with the maximum dimensions of 1380 × 1160 × 1680 mm per item.  
As a modular unit, IBC Drying Tunnel ABT IBC can be integrated into a comprehensive NIEROS® washing system, or work independently as a separate unit.

## PRODUCT SPECIFICATIONS

- Stainless steel DIN 1.4301 (AISI 304)
- Adjustable drying parameters
- Highly sophisticated drying system
- Accelerated air-drying
- Integrated or separate unit
- Low operating and maintenance costs
- Smooth surface finish
- Height adjustable
- IP65 protection
- Electrical connection of 3 × 400 V, 50 Hz
- Fully customized (optional)

Product model	ABT IBC 40	ABT IBC 80
Dimensions L x W x H	3.5 × 3.0 × 5.8 m	4.5 × 1 × 1.7 m
Items of drying	Stainless steel IBCs, bins and others	
Item's max. L x W x H	1380 × 1160 × 1680 mm	1380 × 1160 × 1680 mm
Max. drying capacity per hour	40	80



Highly efficient drying nozzles

# Vacuum-Packed Item Blow-off Tunnel ABT VP



- NIEROS® Vacuum-Packed Item Blow-off Tunnel ABT VP is specially designed to remove residual water from vacuum-packed food after the washing process—its special airflow system blowing off up to 90% of surplus water. Accommodating up to 300 vacuum-packed items of maximum 600 × 400 × 300 mm in size per hour, the ABT VP Tunnel can be integrated into a comprehensive processing line as a modular unit, or work independently as a separate unit, which can be fully customized.

## PRODUCT SPECIFICATIONS

- Stainless steel DIN 1.4301 (AISI 304)
- Adjustable drying parameters
- Smooth surface finish
- Height adjustable
- IP65 protection
- Electrical connection of 3 × 400 V, 50 Hz
- Integrated or separate unit
- Low operating and maintenance costs
- Fully customized (optional)

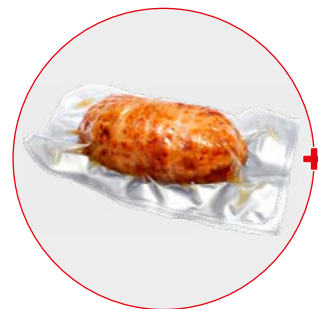

Different types of vacuum-packed food products

Product model	ABT VP
Dimensions L × W × H	2.0 × 0.9 × 1.7 m
Items of drying	Vacuum-packed food items
Item's max. L × W × H	600 × 400 × 300 mm
Max. drying capacity	300

# Sanitizers

## ABOUT NIEROS® SANITIZERS

Hygiene is a crucial factor in many industries, notably in branches such as catering and healthcare. Utilizing specialized chemicals, NIEROS®, a bespoke equipment specialist, can provide a special-purpose sanitizer and introduce various methods of sanitation to effectively clean any object.

## ■ Pack Sanitizing Machine CLT SA



- NIEROS® Pack Sanitizing Machine CLT SA is an effective solution for sanitizing various vacuum-packed products, whether in buckets, bags, tins or on trays. It can accommodate up to 300 items of sanitization with the maximum dimensions of 800 × 500 × 400 mm per hour.

### PRODUCT OPTIONS AND ADDITIONAL EQUIPMENT

A variety of options and additional equipment is available with this model. For more information, please consult NIEROS® experts or distributors. For a complete list of options and additional possibilities, see NIEROS® Washing Machine Options (pp. 67–68) and NIEROS® Additional Washing Equipment (p. 69).

Product model	CLT SA
Dimensions L x W x H	3.1 × 1.1 × 1.6 m
Items of wash	Vacuum-packed products (in buckets, bags, tins and or on trays)
Item's max. L x W x H	800 × 500 × 400 mm
Max. sanitizing capacity per hour	300

### PRODUCT SPECIFICATIONS

- Stainless steel DIN 1.4571 (AISI 316Ti)
- Integrated or separate unit
- Suitable for various vacuum-packed products (in buckets, bags, tins or on trays)
- Vapour extraction fan (optional)
- Mesh conveyor belt
- Smooth surface finish
- Height adjustable
- IP65 protection
- Electrical connection of 3 × 400 V, 50 Hz
- Mobile wheels (optional)
- Fully customized (optional)