

APPROVED FOR MANUFACTURE
 SIGNED..... DATE.....
 PLEASE PRINT NAME.....
 CHANGES MADE AFTER APPROVAL MAY BE CHARGEABLE

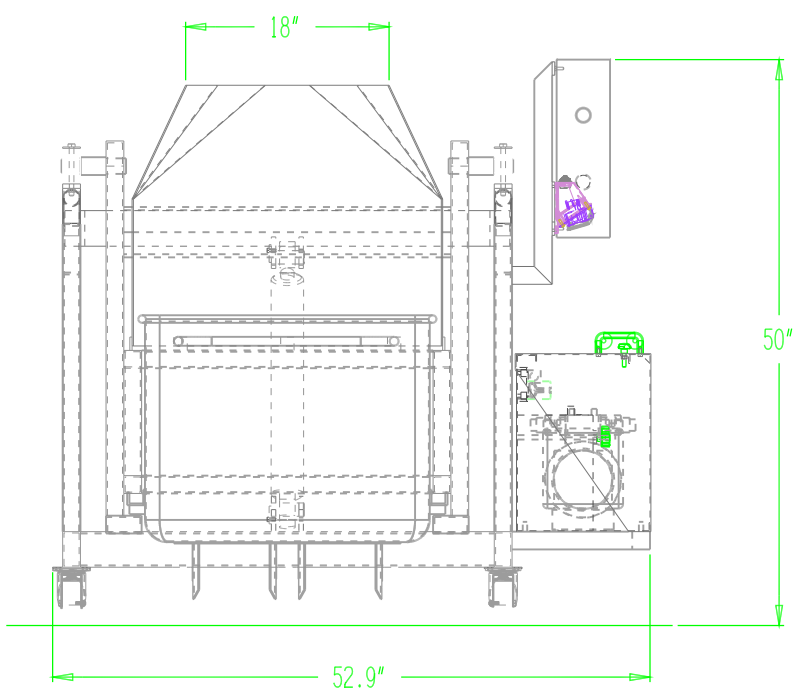
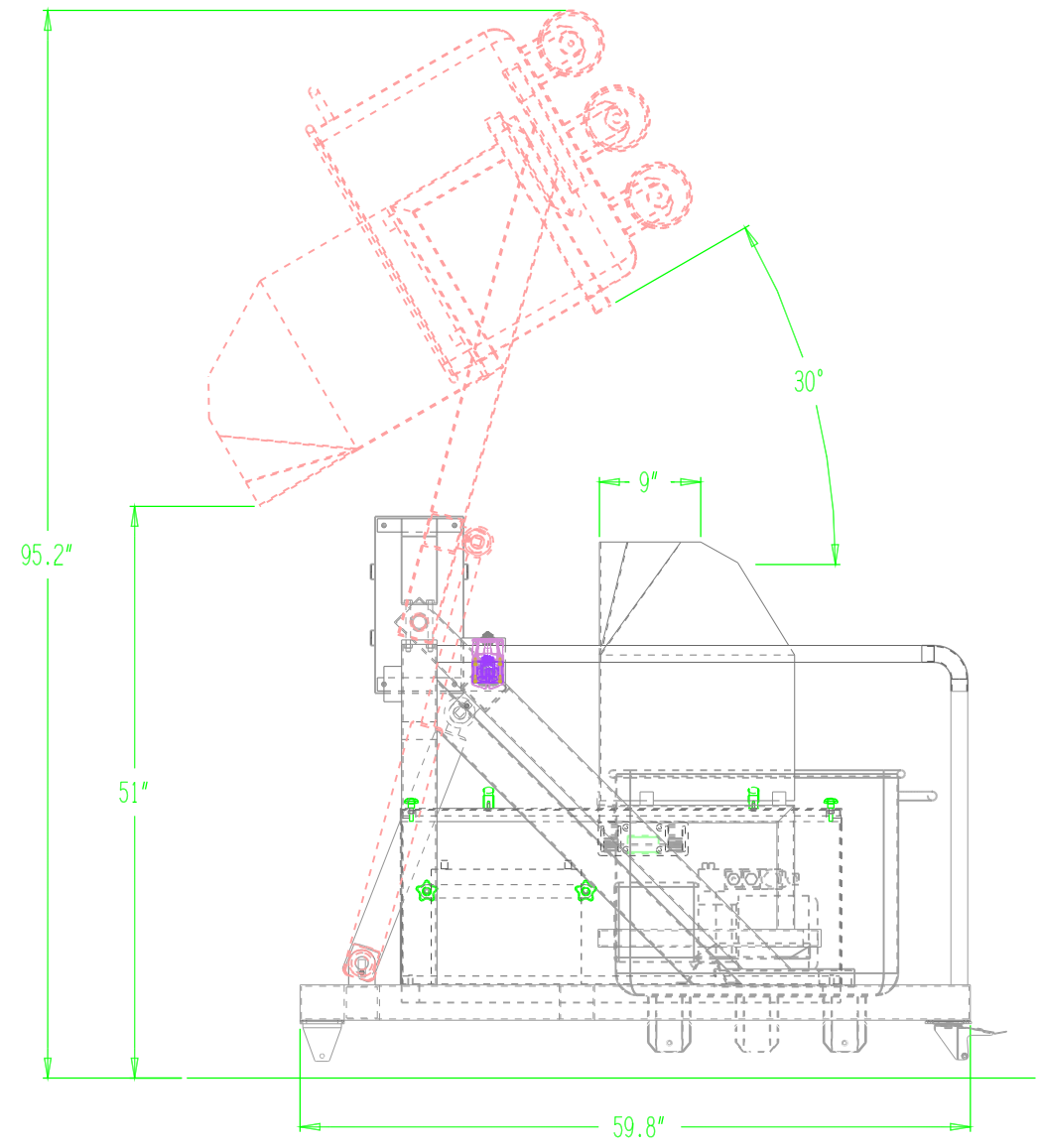
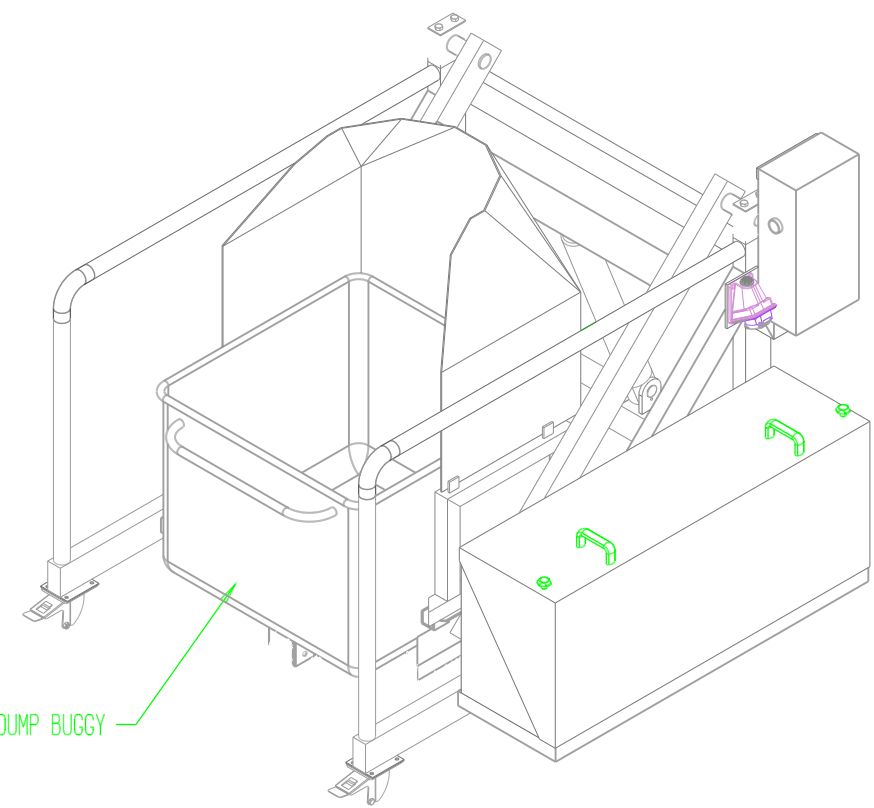
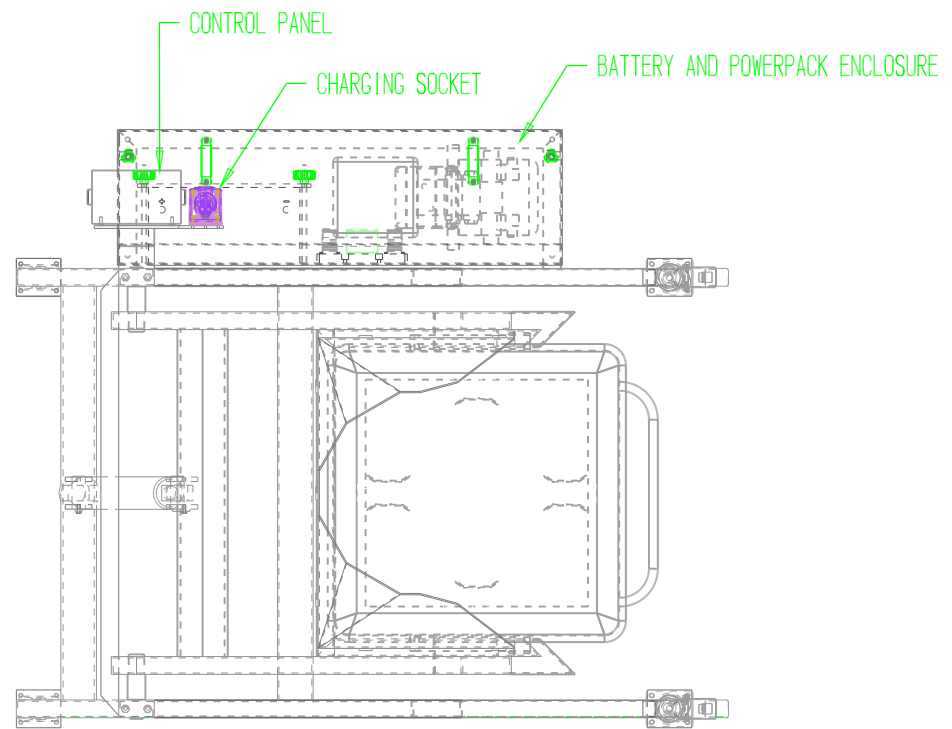

REVISION NUMBER							
CUSTOMER	DRAWING TITLE						
	HYDRAULIC BIN TIPPER						

WELDING NOTE
 STAINLESS STEEL MATERIAL UP TO AND INCLUDING 3mm THICK TO BE TIG WELDED AND MATERIALS OVER 3mm THICK ARE TO BE MIG WELDED UNLESS OTHERWISE STATED.
 REFER TO WELDING PROCEDURES FOR MORE DETAIL.

REMOVE ALL BURRS AND SHARP EDGES	DRAWN	CHECKED	DATE
TOLERANCES : UNLESS OTHERWISE STATED	JPW		27-02-23
FABRICATIONS : +/- 2.0mm	DRAWING NUMBER		
MACHINING : +/- 0.2mm	BP4512-1A		
SHEET METAL WORK : +/- 1.0mm AND +/- 1.0 DEG	DRAWN THIRD ANGLE PROJECTION		