

PAIR OF BRACKETS TO MAKE TIPPER BOLT DOWN SUPPLIED WITH MACHINE

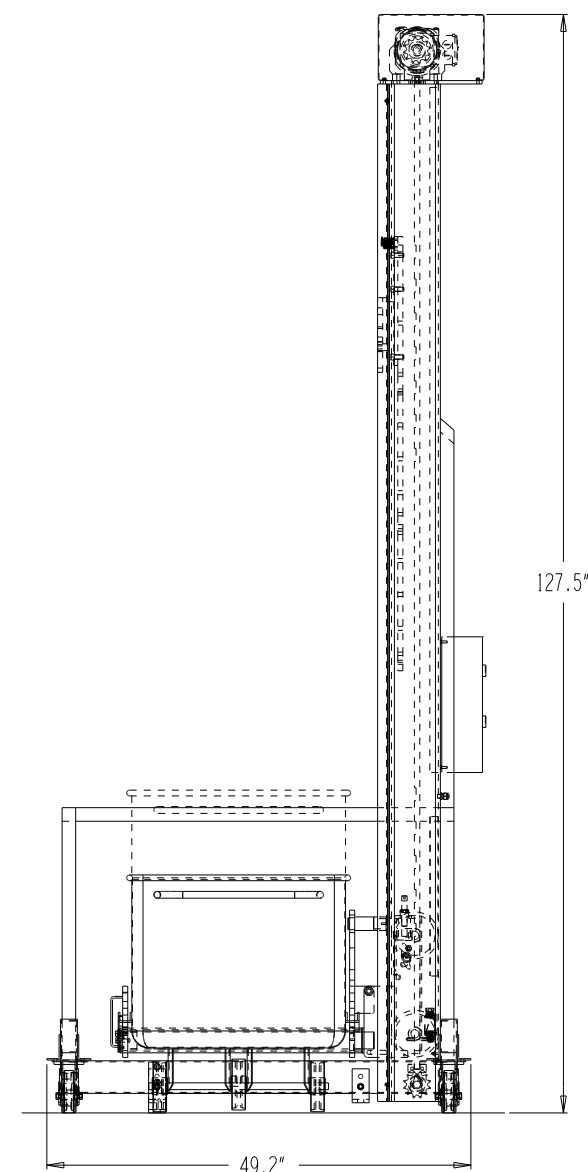
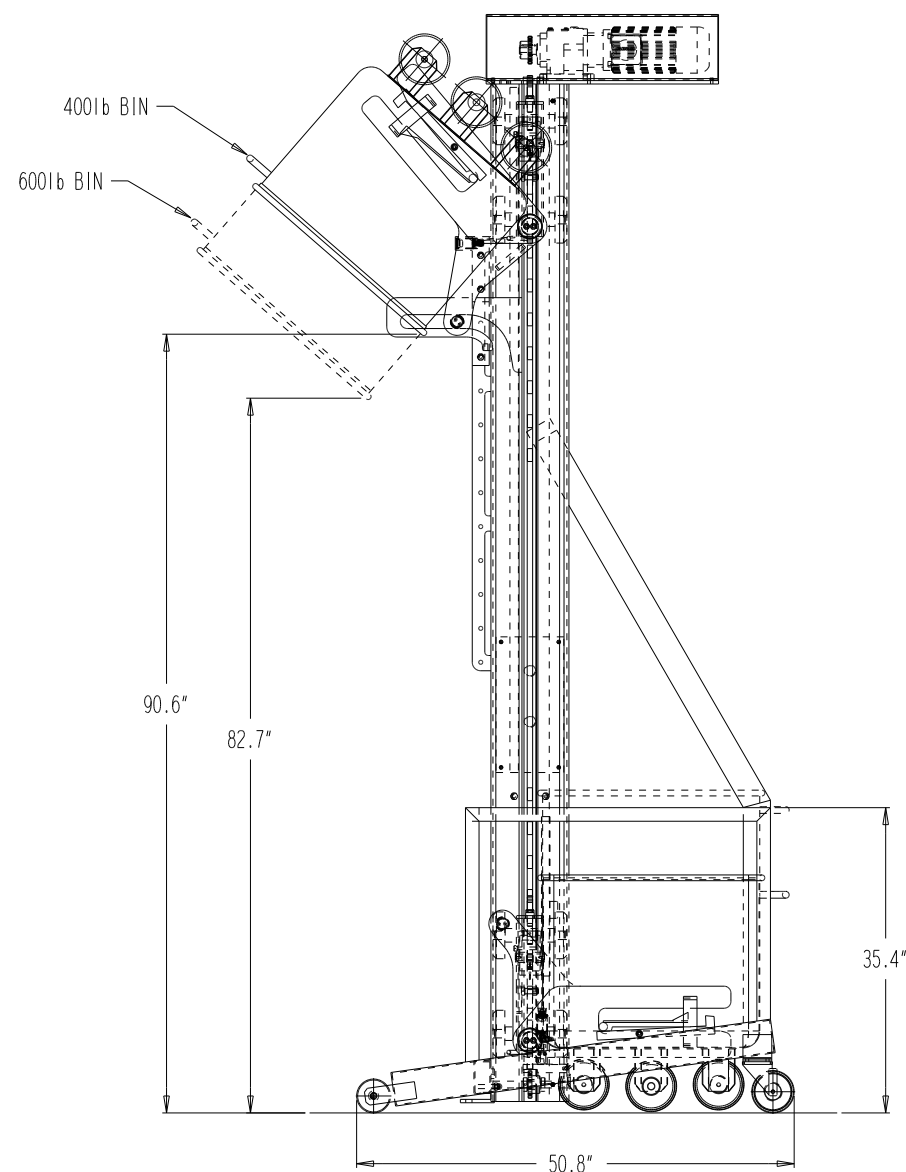

REVISION NUMBER	REVI 12-06-20 JPW								
	COLUMN BRACE ADDED								

CUSTOMER \_\_\_\_\_ DRAWING TITLE  
**SINGLE PILLAR BIN TIPPER**

**WELDING NOTE**  
 STAINLESS STEEL MATERIAL UP TO AND INCLUDING 3mm THICK TO BE TIG WELDED AND MATERIALS OVER 3mm THICK ARE TO BE MIG WELDED UNLESS OTHERWISE STATED. REFER TO WELDING PROCEDURES FOR MORE DETAIL.

REMOVE ALL BURRS AND SHARP EDGES	DRAWN	CHECKED	DATE
TOLERANCES : UNLESS OTHERWISE STATED	JPW		20-09-18
FABRICATIONS : +/- 2.0mm	DRAWING NUMBER		
MACHINING : +/- 0.2mm			
SHEET METAL WORK : +/- 1.0mm AND +/- 1.0 DEG			
DRAWN THIRD ANGLE PROJECTION			